

## INSTALLATION AND MAINTENANCE MANUAL FOR UNIFREM 400 250 ÷ 630 FREQUENCY CONVERTERS





## Contents:

1	VONSCH product warranty certificate .....	5
2	Installation .....	7
2.1	Safety instructions.....	7
2.2	Main circuit – block scheme of the converter.....	8
2.3	Converter assembling and installation.....	9
2.3.1	Starting the converter using the main contactor .....	10
2.4	Important warnings .....	10
2.4.1	Protection against overvoltages .....	10
2.5	Frequency converter protection.....	11
2.6	Connecting a motor using a cable over 100, resp. 50 m .....	11
2.7	Measurement and revisions of the FC.....	12
2.8	Cooling .....	13
2.9	Dimensioning the cables to the FC .....	14
2.9.1	Input cables .....	15
2.9.2	Output cables .....	15
2.9.3	Cables conduction .....	16
2.10	Grounding.....	17
2.11	FC operation with a residual-current device .....	18
2.12	Maintenance .....	19
3	Technical specifications .....	20
3.1	General technical data .....	21
4	Technical drawings .....	22
4.1	Connection diagram of the UNIFREM 400 frequency converters .....	22
4.2	UNIFREM 400 converters terminals description and the way to connect the supply phases and the output phases from the converter .....	25
4.2.1	Power terminal X0 .....	26
4.2.2	Control terminal X1 .....	26
4.2.3	Serial link RS485 – RS485 ( CANON) port connection method.....	27
4.2.4	External control examples for the X1 terminal using binary inputs.....	27
4.2.5	Method of connecting the potentiometer to the X1 terminal.....	28
4.2.6	Method of connecting the analog inputs of converter .....	28
4.2.7	Method of connecting the analog outputs of converter .....	29
4.2.8	Method of connecting sensors to the X1 terminal.....	29
4.2.9	Connecting temperature sensors of the motor - PT100 , PTC to the X1 terminal .....	30
4.2.10	Connecting measuring and display devices to the analog output of the X1 terminal .....	31
4.2.11	Relay terminal X2 .....	32
4.2.12	Example of a relay connection option KA1, KA2, KA3.....	32
4.3	Dimensioning of braking resistors .....	33
4.4	Sine filter.....	33
4.5	Motor chokes .....	33
4.6	IRC connection to frequency converter UNIFREM 400 .....	34
4.7	UNI-PB DP extension module to connect the converters to PROFIBUS DP .....	35
4.8	Resolver sensor type connection to frequency converter UNIFREM 400 .....	36
4.9	UNIFREM 400 converter connection using a serial line .....	37
4.10	OPTION (optional accessories).....	38
4.10.1	Removable control panel UNIPANEL-1.....	38
4.10.2	Connecting multiple frequency converters to the UNIPANEL-1 control panel.....	39
5	The procedure for uploading firmware.....	40
6	Appendix.....	43
6.1	Quality certificate – organization management system .....	43
6.2	ES Declaration of conformity.....	45

6.2.1	europa harmonized standards .....	45
6.2.2	slovak and europa harmonized standards.....	46

# 1 VONSCH product warranty certificate

**a, Converter tests:**

Frequency converter is properly tested by the manufacturer before the expedition. Product properties comply with the technical documentation, provided it is installed and used according to the instructions and recommendations stated in the technical documentation and the operating manual.

**b, Warranty period:**

Warranty period for the UNIFREM 400 converter is 25 months from the expedition date.

**c, Warranty conditions:**

The warranty covers only errors and defects caused by faulty production or used components.

The manufacturer performs warranty repairs in the warranty period free of charge. For a warranty claim, a properly filled out and confirmed warranty certificate is required. The warranty period is extended by the time the frequency converter was in repair.

Customer claims the warranty repair by the manufacturer. The customer delivers the UNIFREM 400 type series frequency converter to VONSCH spol. s r.o., or VONSCH charges the warranty repair delivery costs to the customer. Under warranty, material and work related to the diagnostics and replacement on the frequency converter are covered.

**Warranty does not cover defects caused by:**

- 1, Customer - user fault by mechanical damage (for example during the transport or a fall) or when using it in conflict with the technical documentation, wrong installation or if the fault was caused by unauthorized interference with the product.
- 2, The device is damaged by externalities (internal converter components dusting) or natural damages (over-voltage damages caused by a lightning, fire, damage by water-flood)
- 3, Wrong storage conditions, installation in conflict with the recommended installation, natural damage, mainly caused by electrical quantities of unacceptable size

Frequency converter type	<b>UNIFREM 400</b>
Serial number:	
Production date:	
Expedition date:	
Commissioning date:	

**Signature and stamp of the manufacturer:**

**Manufacturer notes:**

**Manufacturer notes:**



## 2 Installation

It is forbidden to duplicate this document and use this document besides the installation of VONSCH frequency converters without a written approval. Violating this prohibition causes the offender to be liable for damages.

VONSCH s.r.o. made sure that the content of this document corresponds with the described hardware and software. **Because of continuous adding and improving of the parameter, VONSCH s.r.o. reserves the right for possible differences of the manual from the reality - the product can contain functions that are not described in this manual.**

### 2.1 Safety instructions

The goal of the following warnings, caution tips and notes is to ensure your safety and to serve as a resource to prevent damage to the product and connected devices.

**Special warnings, caution tips and notes** related to the specific tasks are stated on the beginning of corresponding chapters and again on the critical text points of this manual.

**Read these informations carefully, because they are listed for your personal safety and can extend the lifetime of your frequency converter and connected devices.**



#### **WARNING !!!**

Before you install and commission the frequency converter, read the warnings and recommendations on the following pages very carefully!

Ignoring these warnings and recommendations can lead to serious, or possibly deadly accidents!

In violation of valid safety standards and regulation, the manufacturer is not liable for damages and harms.

Assembling and assembling related work can be only performed by persons qualified according at least to § 21 to 24 of the Regulation 508/2009 B. of I.



#### **ATTENTION!**

- Before you start working with the frequency converter, discover its functions and how to manipulate with it.
- Make sure that no person without proper skills can manipulate with the converter!
- Working with frequency converters can only be performed by qualified persons that need to be familiar with the threats and precautions regarding the installation and operation of the frequency converter described in this operation and maintenance manual.
- Access to the frequency converter is forbidden to children and unauthorized persons!
- Converter can only be used for the purposes recommended by the manufacturer!
- On certain components of the frequency converter, dangerous electric voltage is present and the converter feeds rotating mechanical devices. If you do not proceed carefully according to this manual when putting the converter into operation, serious or deadly accidents, or massive damages on the property can occur.
- Failure-free operation of the converter depends also on a adequate transport to the operation area, professional storage, installation, commissioning and setting of individual parameters!
- Frequency converters are power electronics devices and dangerous voltages occur on certain components of the converter.
- Dangerous voltage is present on the capacitors in the DC link even after switching off the converter. Because of this, it is allowed to open the converter only after 5 minutes after

disconnecting the converter from the power supply, when the power capacitors in the DC link are discharged. Then it is possible to start working with the converter, with the cables to motor or with the motor.

- When reconnecting the motor cables, always check the correct phase sequence.
- Even when the motor is not running, there can be dangerous voltage on some power terminals of the converter.
- When the converter is damaged, motor rotation (drive movement) can occur even without a start command.
- After a power supply outage and restoration, the converter can automatically restart and move the drive under certain circumstances (appropriate setting of the frequency converter).

## 2.2 Main circuit – block scheme of the converter

UNIFREM 400 frequency converter during its operation rectifies the three phase AC power supply and using the power semiconductor switching elements generates three phase output voltage of various size and frequency and so the speed of the connected motor is smoothly controlled.

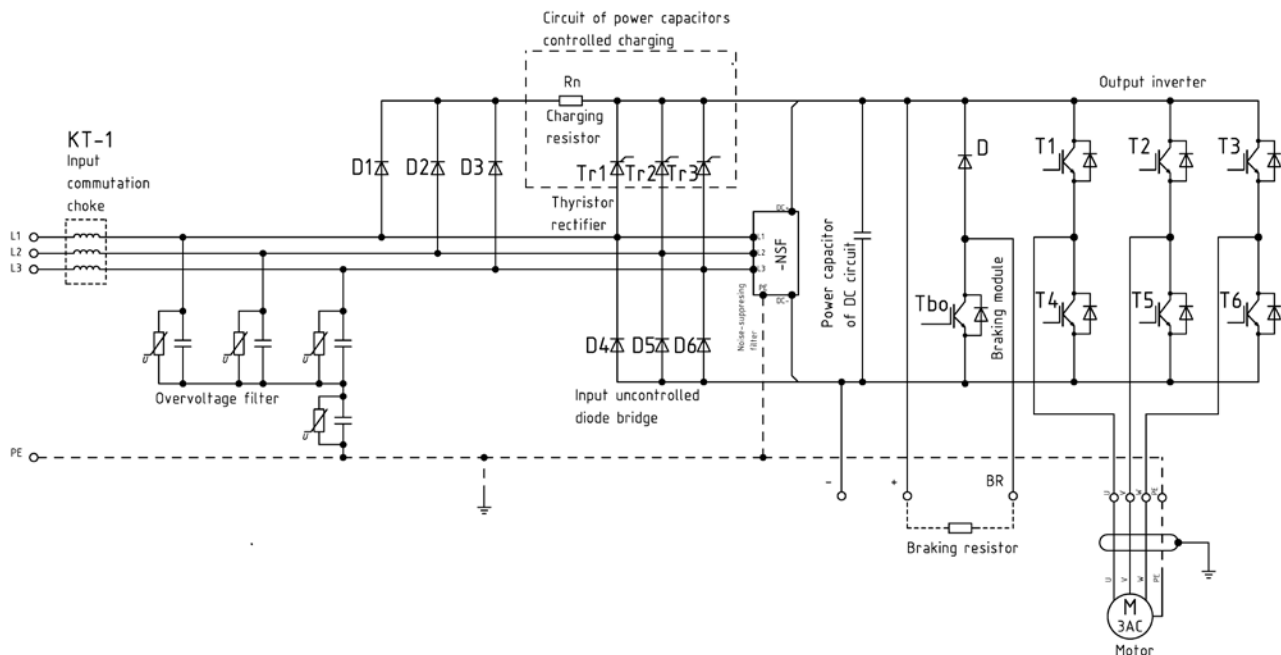

**Main components of the frequency converter:**

Component	Description of the function
<b>Input thyristor - diode rectifier</b>	Rectifies 3-phase AC power supply voltage to DC voltage.
<b>Capacitive bank - power capacitor of a DC inter-circuit</b>	Accumulates energy, which stabilizes the DC inter-circuit voltage.
<b>Output six - pulse IGBT inverter</b>	Transforms DC voltage to AC and vice versa. Load operation is managed by IGBT switching.
<b>Input - commutation choke</b>	Restricts the consumption of high harmonic currents from the power supply.
<b>Overvoltage and noise - suppressing filter</b>	Restricts peaks in the power supply and eliminates interfering voltages generated by the frequency converter operation. The result is high electromagnetic immunity.
<b>Braking module and resistor</b>	Provides energy to heat transformation in regenerative operation mode of motor.



## 2.3 Converter assembling and installation

Reliable operation is conditional to the converter being installed and put into service by workers with corresponding qualification and compliance with instructions and warnings that are stated in this operation and maintenance manual.

It is necessary to respect general safety instructions when working with high-current devices, use the tools expertly and use protective personal utilities according to relevant regulations.

Ignoring the stated rules can lead to death, serious injuries or large property damage.

Make sure that the frequency converter is installed in a dry place, protected against humidity and direct sunlight, splashing or dripping water!

Over and under the converter, it is necessary to leave free space for the cool air circulation.

On every side of the converter, it is necessary to leave free space because of cooling reasons.

In case when the converters are installed over each other, make sure they are cooled properly that there is sufficient free space and there is no local heat accumulation.

After installing the converter and functional test, make sure that the temperature in the converter environment does not exceed the allowed value 40°C. Overheat of the power electronics threatens if the temperature of cooling air is exceeded during operation of the drive. In this case, it is necessary to ensure cooling or ventilation in the room, where the frequency converter is installed.

Eliminate excessive shaking and vibrations.

On printed circuit boards, highly sensible semiconductor MOS components are installed, which are specially sensible to static electricity. Because of this, do not touch it by bare hand or metal objects. For connecting the control and power conductors, it is only possible to use an insulated screwdriver.

Arbitrary changes, using replacement components not recommended by the manufacturer, can cause power supply outages, fires or serious injuries.



**To enable the start, it is necessary to connect the safety input (EN13849-1 cat.3) of the converter to the voltage of +24V (connect the terminals X1:7 - X1:8).**

Switched off safety input turns off the IGBT transistors driving by software and turns the power module by hardware.

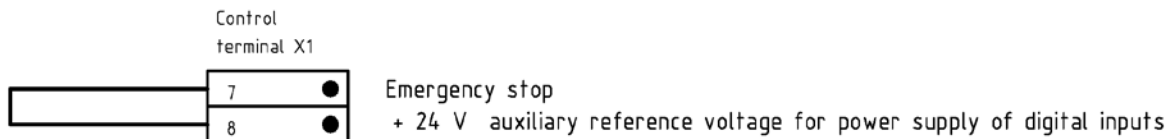

*Simple connection of terminals X1:7 - X1:8*

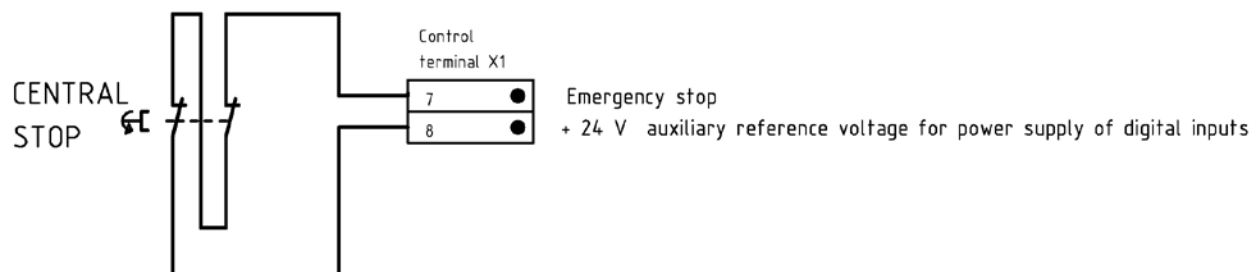

*It is possible to disconnect the safety input from the converter power supply using the CENTRAL STOP button.*

### 2.3.1 Starting the converter using the main contactor

Before you start and configure the converter it is necessary to make sure that the power supply voltage is compatible with the power supply voltage range of the frequency converter. Using incompatible power supply can irreparably damage the converter. For safety reasons, it is recommended to equip the converter with a main contactor for safe disconnection of the power component of the converter from the power supply.

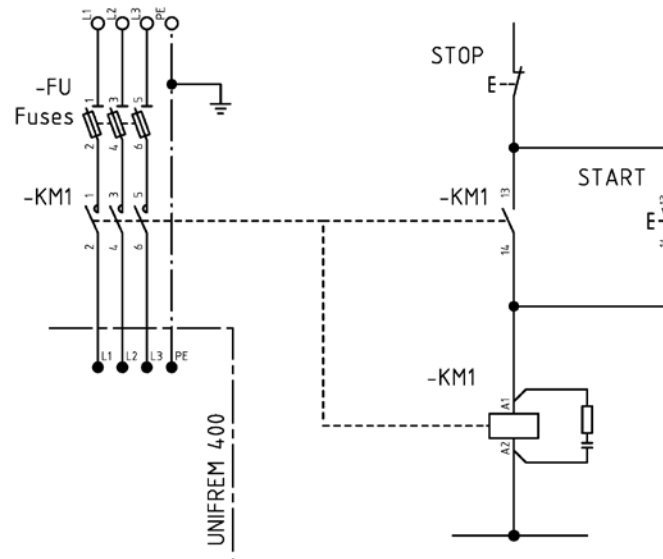

## 2.4 Important warnings

In case that the power electronics devices (for example frequency converters) are operated close to switching components (contactors, relays, etc.), or they are operated on the same power grid as the switching components, we recommend to perform following precautions to eliminate the switching components interference to minimize EMC (electromagnetic compatibility - it represents the ability if an electric/electronic device to work properly in a electromagnetic environment. Also, this device can not disturb or interfere with any device or system in the same area).

- on contactor or relay (induction load) coils and other switching components, connect suppressing RC filters or diodes.
- for external control, regulating or measuring circuits use the shielded conductors.
- conductors that represent the source of an interference (for example power conductors and contactor control conductors) need to be wired in a distance of at least 20 cm from the control conductors.

### 2.4.1 Protection against overvoltages

It is not recommended to use the frequency converter on devices, which operation involves short term power supply disruptions on all, respectively one inlet phase. (For example on electric connection through a ring collector respectively a trolley conduct of improper design).

*During a power supply phase disruption, the converter can evaluate under-voltage in a DC circuit and automatically turn off and automatically turn on in a normal power supply state - converter undervoltage occurs during a power supply phase disruption only on higher frequencies, so the converter can cycle.*

**During short-term electrical energy disuptions, forbidden voltage peaks can occur that can cause a converter error.** So if there are reasons for forbidden voltage peaks occurrence (for example trolley conduct arcing), it is necessary to add special accessories to the input of the frequency converter:

- overvoltage filter, which prevents overvoltage peaks. Without this protection, the warranty does not cover damages to the converter caused by overvoltage peaks.

## 2.5 Frequency converter protection

Input current value is increased by the share of high harmonics, so it is necessary to dimension the input fuses accordingly.

Practically every manufacturer recommends the fuses of corresponding types and performances in the technical documentation.

Main advantage of quick fuses is to minimize further damage.

**Quick fuses of the type: gG** fuse only the short circuit, **gR** fuse short circuit + overload

Example: In case of fault occurring on the input diode of the rectifier (wire from the diode) and a quick fuse is used, this fuse is immediately destroyed, but if a regular fuse is used (for example gG) the fuse conducts for a short time and the "wire" of the diode conducts AC voltage to electrolytic capacitors in DC converter circuit, which causes fault of these electrolytic capacitors.

Specific protection between separate components of the converter (for example conveter - brake resistor - motor choke - sine filter) does not require EN 50178 part: 8.3.3.2.

For protection on the frequency converter output against overload and/or a short circuit, it is allowed to use a suitable automatic electronic blocking system. EN 50178 part: 8.3.3.2.

**It is not necessary to protect the UNIFREM 400 frequency converter output - protection is secured by the frequency converter.**

## 2.6 Connecting a motor using a cable over 100, resp. 50 m

Cable capacity (the longer the cable, the bigger the capacity) causes the need for the frequency converter to feed additional current during every commutation to charge the cable capacity between the motor and the converter. This current totalized with the motor current can be so high that it exceeds the maximal allowed current of the converter. Converter turn off follows with the error state "Converter overcurrent" of "Output short circuit". Total length of the supply cable from the converter to the motor (or the total count of the cables to the motors) can not exceed 100m (50m by a shielded cable). When using longer cables, it is necessary to take precautions to eliminate the cable length effects to the converter operation: *adding motor chokes or a sine filter eliminates the cable capacity effects*. Without a motor choke, it is possible to use a maximal 100m long cable between the converter and the motor. When the distance is over 100m, it is necessary to use motor chokes on the converter output, eventually every 100m.

In case a shielded cable is used, the total length of this cable should not exceed 50m. When the distance is over 50m, it is necessary to use motor chokes on the converter output, eventually every 50m. Ideally, it is best to use a sine filter to eliminate the effects of the cable capacity, which causes the cable line to line voltages to have a sinusoidal shape.

Also, it is ideal to use this filter on large distances between the motor and the converter. On any cable type or length, it is sufficient to use one sine filter. To ensure a complex EMC on the output side of converter, it is necessary to use a special EMC sine filter. The all voltages are sinusoidally shaped on the output of sine filter.

## 2.7 Measurement and revisions of the FC

When revising enclosures with frequency converters, we proceed exactly as when revising other enclosures according to valid standards EN 33 1500, EN33 2000-4, -6.

For frequency converters, EN 601 46-1-1, 1-1/A1, 1-3, EN 61800-3 apply.

**For measuring the frequency converters, it is necessary to provide:**

- when measuring the insulation states or the transition resistors, the conductors need to be disconnected from the frequency converter terminals (input L1, L2, L3 and the output U, V, W).

Similarly, the conductors need to be disconnected from all control terminals.

(Note: power units in the FC with the supply voltage of 1 x 230V are used for 600 V, on FC with the supply voltage 3 x 400V are used for 1200 V)

- if insulation states or the transition resistance measurement is performed on the enclosure and it is possible that output voltage can access the frequency converter (e.g. measuring device voltage), its terminals need to be short-circuited and connected to PE.

- frequency converter measurement can be only performed by its manufacturer

- high voltage insulation test can never be performed on cables connected to the FC!!!

Always check using a multimeter with an impedance of at least 1 M $\Omega$ :

1. Voltage between the output phases of the converter L1, L2, L3 and the frame is close to the value 0 V.

2. Voltage between the UDC+ terminals (routed positive terminal of a DC link) and UDC- (routed negative terminal of a DC link) and the frame is close to the value 0 V.

- Check the insulation before connecting the converter to the power supply. Do not start any insulation tests without disconnecting the cables of the converter.

### CHECKING THE INSULATION STATES OF THE MOTOR CABLES

1. Check, if the motor cable is disconnected from the output terminals of the converter U,V,W and from the motor.

2. Measure the insulation resistance of the motor cable between every conductor phase as well as between each phase and the protective grounding conductor using the measuring voltage of 1 kV DC.

Insulation resistance must be higher than 1 M $\Omega$  in an environment temperature of 20°C.

3. After reconnecting the motor cables, always check the correct phase order.

### CHECKING THE INSULATION STATE OF NETWORK CABLE

1. Check, if the power supply cable is disconnected from the converter input terminals L1,L2,L3 and from the grid.

2. Check the insulation resistance of the power cable between every conductor phase, as well as between each phase and the protective grounding conductor using the measuring voltage of 1 kV DC.

Insulation resistance must be higher than 1 M $\Omega$  in an environment temperature of 20°C.

## CHECKING THE INSULATION STATE OF MOTOR

1. Disconnect the motor cable from the motor terminal and disconnect the bridging connections in the motor terminal box.
2. Measure the insulation resistance of each motor winding. Measuring voltage must equal at least the motor nominal voltage but not exceed 1000V DC.

Insulation resistance must be higher than 100 M $\Omega$  (insulation resistance depends on the motor type) in an environment temperature of 20°C.

Moisture inside the motor casing will reduce the insulation resistance. If moisture is suspected, dry the motor and repeat the measurement.

## CHECKING THE INSULATION STATE OF BRAKING RESISTOR

1. The braking resistor must be disconnected from the converter terminals **+** and **BR**.
2. Connect the R+ and R- conductors of the resistor cable together. Measure the insulation resistance between connected conductors and PE protective grounding conductor using a measuring voltage 1 kV DC.

Insulation resistance must be higher than 1 M $\Omega$  in an environment temperature of 20°C.

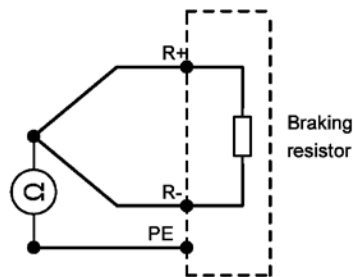

## 2.8 Cooling

Cooling of the UNIFREM frequency converter must be ensured during its installation in a way, to comply with:

Cooling media temperature see EN 50178 part: 6.1.1.2.  
For air and gas cooling: min + 5°C, max + 35°C

Access parts temperature see EN 50178 part: 7.1.7.5.

Covers that can be reached by hand:  
Metal: + 70°C, Insulation material + 80°C  
Resources controlled by hand:  
Metal: + 55°C, Insulation material + 65°C

## 2.9 Dimensioning the cables to the FC

See EN: 50178 part: 8.3.3.1. to 8.3.3.4.

When dimensioning cables, it is necessary to consider:

Dimensioning the cable length not only for the current but also considering the voltage loss on the cable that should not exceed 1,5 to 3%.

### Connecting the power conductors and dimensioning of ballast fuses:

In the table, we stated recommended cross-sections of inlet conductors to the frequency converter when using a commutation choke. When dimensioning, it is advisable to take the cable length, distance from the transformer, short circuit power of the transformer and so on into account.

**For converter input protection, it is necessary to use fuses with a gR characteristics** (fuses to protect the semiconductors). In the table, we stated recommended fuses to protect the power cord against short circuit, valid when using a frequency converter with a commutation choke KT1.

Converter type	Cross-section of the inlet cables: <b>CYKY-J</b> 4 x cross-section to the converter enclosure: Cu [ mm <sup>2</sup> ]	Cross-section of the inlet conductors of the <b>HO7V-K</b> type into the converter in the enclosure Cu [ mm <sup>2</sup> ]	Cross-section of the output conductors of the <b>HO7V-K</b> type from the converter in the enclosure Cu [ mm <sup>2</sup> ]	Cross-section of the output cables: <b>CYKY-J 4 x cross-section</b> <b>NYCY 3 x cross-section</b> <b>NYCWY 3 x cross-section</b> <b>ÖLFLEX® 4 G</b> from the converter enclosure Cu [ mm <sup>2</sup> ]	Recommended preprint fuses of the gR type [ A ]
<b>UNIFREM 400 250</b>	2 x 95 ÷ 2 x 120	2 x 95	2 x 50 ÷ 2 x 70	2 x 95 ÷ 2 x 120	500
<b>UNIFREM 400 315</b>	2 x 150	2 x 95 ÷ 2 x 120	2 x 70	2 x 120 ÷ 2 x 150	630
<b>UNIFREM 400 400</b>	2 x 180 ÷ 2 x 240	3 x 70	2 x 95	2 x 180	2 x 400
<b>UNIFREM 400 500</b>	3 x 150	3 x 95 ÷ 3 x 120	3 x 70	2 x 240, 3 x 150	2 x 500
<b>UNIFREM 400 630</b>	3 x 240	4 x 95	3 x 95 ÷ 3 x 120	3 x 180 ÷ 3 x 240	2 x 630

#### *\*Note to dimensioning of cables:*

*The table shows the minimum possible cable cross sections. The designer must evaluate the real dimensioning according to the voltage drop on cables, on the type of cable storage and ambient temperature. Converters with 400V power supply and with power above 315 kW are special products made by customer requirements.*



When dimensioning the output cables to the motor, it is recommended the use of shielded cables type of **NYCY 3 x cross-section**, **NYCWY 3 x cross-section** or **ÖLFLEX® 4G** to minimize radio frequency interference. The principles of cables conduction are listed in the section 2.9.3 Cables conduction.



### 2.9.1 Input cables

EN 50 178 part: 8.3.3.1.

When dimensioning input cables into the frequency converter, it is necessary to consider high harmonic currents, which cause additional heating of the input cable conductors. Because of this, it is necessary to dimension the cable cross-section by cca 30% more against the original concept, or use a 3-phase commutation choke KT-1 at the input.

On input cables, no major increased emission into the environment occurs, so there is no reason to use shielded cables for the converter power supply.

### 2.9.2 Output cables

EN 50 178 part: 8.3.3.3.

When dimensioning output cables from the converter to the motor, it is not necessary to dimension the cable cross-section - output current of the converter only contains the first harmonic.

Converter output, regardless of the output frequency, contains pulses with voltage approximately 1.35-times higher than the power supply voltage with a very short starting period (this is valid for all converters using the modern IGBT inverter technology). Pulse voltage on the motor terminals can be almost double the size, it depends on the motor cable features, which can **increase the motor insulation stress**. Drives with steep voltage pulses can cause the current pulses transition through the motor bearings that can lead to a **gradual eroding of groove bearings**. Considering the EMC standards, it is necessary to use shielded cables to the motor, or connect a special **EMC sine filter (see the chapter 4.4 Sine filter)** to the output, which filters the output impulse voltages of the converter to sinusoidal shape voltages of variable frequency and amplitude.

Every cable has a certain capacity (core against another core, core against PE, core against the shield). The longer the cable, the higher the summary value of the distributed capacity. Shielded cables have higher capacity than unshielded cables.

Considering the fact mentioned above, the converter needs to overcharge the cable capacity from plus to minus and vice versa during PWM modulation in every impulse, normal current on the converter output is increased by these short term "capacity" currents. In extreme cases, the summary short term current value can reach a level where the converter turns off and signals "overcurrent" or "short circuit".

Standard cable length to the motor is approximately 100m for generic and 50m for shielded cables. On longer distances, converter stops can occur caused by "capacity currents". On distances exceeding the stated values, the frequency converter manufacturers recommend to connect motor chokes or sinusoidal filter to the converter output, which will interact with the output voltage of the converter and eliminate capacity current peaks and motor insulation stress.

### Grounding of the output motor cable shield

Motor cable shield must be grounded at the side of converter and at the side of motor. For minimum radio - frequency interference, grounding of the motor cable shield on the side of the converter is realised in layout of the shield with 360° gripping in EMC industrial bushing and braided shield is conducted away in the defined shape and connected to the protective terminal PE of the converter.

Grounding of the cable shield on the side of the motor is realised in layout of the shield with 360° gripping in EMC industrial bushing or braided shield is conducted away in the defined shape and connected to the protective terminal PE of the motor. Cross-section of the shield must be at least 1/10 of the phase conductor to effective suppression of radiated and conducted radio frequency emissions. **Cross-section of the shield must meet requirements for the PE conductor.**

### Conditions are met:

- when using shield made of the same metal as the phase conductor
- shield cross section must be at least 50% of phase conductor cross section

A separate PE conductor is required if the shield does not meet the requirements of STN EN 61439-1. Minimum cross-section of the corresponding protective conductor (STN EN 61439-1 – chap.11.10, tab.5):

Cross-section of the phase conductors $S$ (mm <sup>2</sup> )	Minimum cross-section of the corresponding protective conductor $S_P$ (mm <sup>2</sup> )
$35 < S \leq 400$	$S/2$

The better and tighter the shield of the output cable, the lower the emission level and bearing currents and the level of wear reduces.

Defining the shape of the braided shield and 360° gripping of the braided cable shield in EMC bushing :

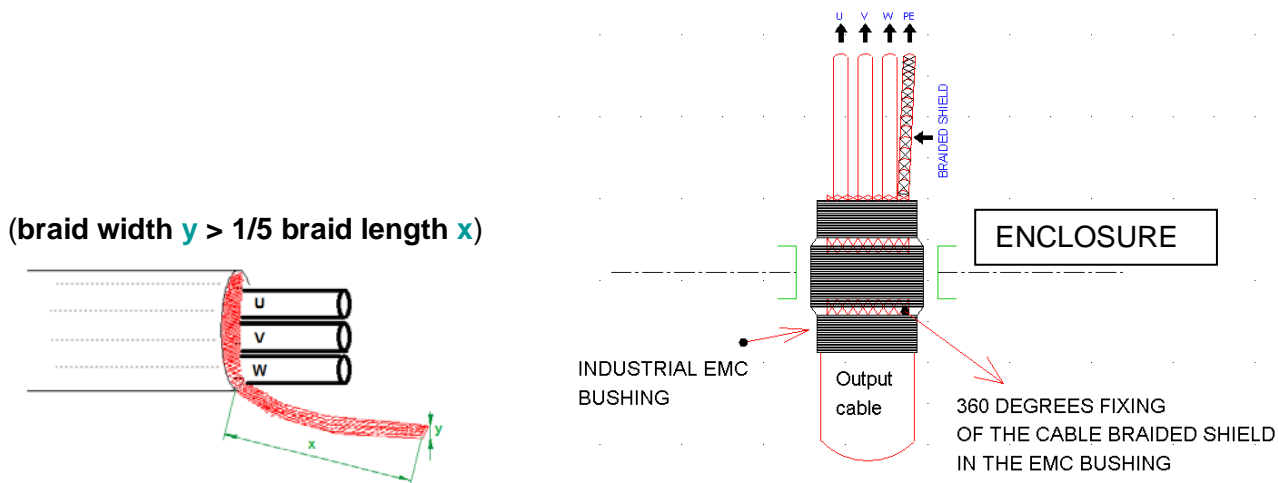

### 2.9.3 Cables conduction

During installation, power cables are stored separately from conductors with a low level signal (sensors, PLC, measuring devices). Control circuits must be separated from the power circuits. When using cable channels, power, control or motor cables are not stored into the same channel to decrease the electromagnetic interference caused by quick voltage changes on the converter output. If it is necessary to cross power and control cables, they need to cross at the right angle. Motor cables are stored sufficiently distant from other cables. If the cables are stored parallel on a long distance, it is necessary to keep a minimum distance between the cables.



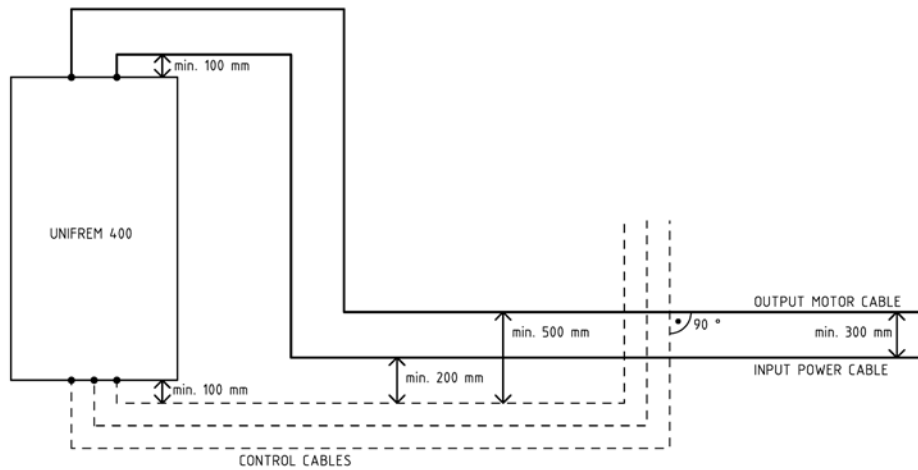

Cables conduction

## 2.10 Grounding

EN 50 178 part. 4.4.

**Grounding in an electrical device is required not only to decrease interference effects, but mainly for personal safety. When a conflict between these two requirements occurs, personal safety always comes first. Considering the nature of electrical device operation, it is necessary to ground the converter, motor and adjacent devices.**

**Personal safety is secured at all circumstances and the electromagnetic emission and interference sensitivity are decreased.**

3-phase frequency converter does not use the PE conductor by its nature, much less the N conductor. Frequency converters are devices with impulse operation of the power components, and this causes interfering currents during its operation. These emerging currents are brought to the metal case of the converter and further linked to the converter ground.

For quality grounding reasons, the standard EN 50178 part 5.3.2.1. prescribes the grounding cross-section of at least 10mm<sup>2</sup> even for low power. *Minimal cross-section is defined because of mechanical strength!!!*

Since the UNIFREM 400 frequency converter contains a HF „RFI“ filter which restricts the HF interference access to the power supply system of the converter, these leakage currents are of higher value, because the HF filter contains also an "Y" capacitor connected to the PE.

Because of this reason the leakage currents of the UNIFREM 400 frequency converter are higher than 3,5 mA on AC, respectively 10mA on DC and the frequency converter must be well grounded.

### Text EN 50178 part 5.2.11.1.:

If the leakage current is higher than the limit values of 3,5mA on AC and 10 mA on DC, duplication of the protective conductor must be secured.

### Text EN 50178 part 5.3.2.1.:

If the usual leakage current in a firmly attached electrical device exceeds the value of 3,5mA on AC alebo 10mA on DC, one of the conditions must be met:

- a, protective conductor cross-section needs to be at least 10mm<sup>2</sup> Cu
- b, two conductors with identical cross-sections as the power conductor

### Connecting multiple converters to the ground:

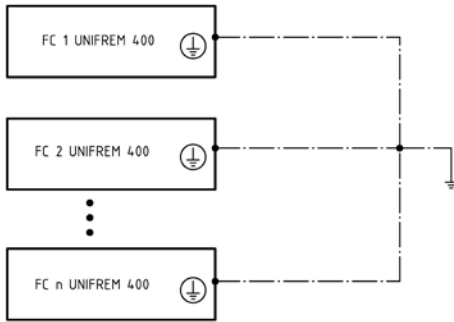

It is not recommended to connect grounding cables in a bundle or in series.

## 2.11 FC operation with a residual-current device

It is possible to use the residual-current device only if:

- converter is not equipped with an EMC filter
- residual-current device is of the "B" type (increased endurance against disabling during DC and AC currents with a pulse component and electromagnetic field interference)
- leakage current of the protector is 300mA
- zero conductor of the power supply is grounded
- one protector protects only 1 frequency converter
- maximal motor cable length is 100m (50m for shielded cables)
- when installing multiple converter, one residual-current device per converter is required

### EN 50178 part 6.5.:

Frequency converters that contain an EMC filter can not be connected through a residual - current device!!!

**UNIFREM 400 Type series frequency converter contains an integrated EMC filter, therefore it is not possible to use a residual-current device on its input!!!**

### Text EN 50178 part 5.2.11.2.:

Before connecting an electronic device to a power supply protected by a residual-current device, compatibility of this device with the residual-current device needs to be checked.

If it is necessary, protection must be secured using other methods - EN 50 178 part 5.3.2.3..

## 2.12 Maintenance

Frequency converter installed in a suitable environment requires minimal maintenance. Converter should not be exposed to direct sunlight.

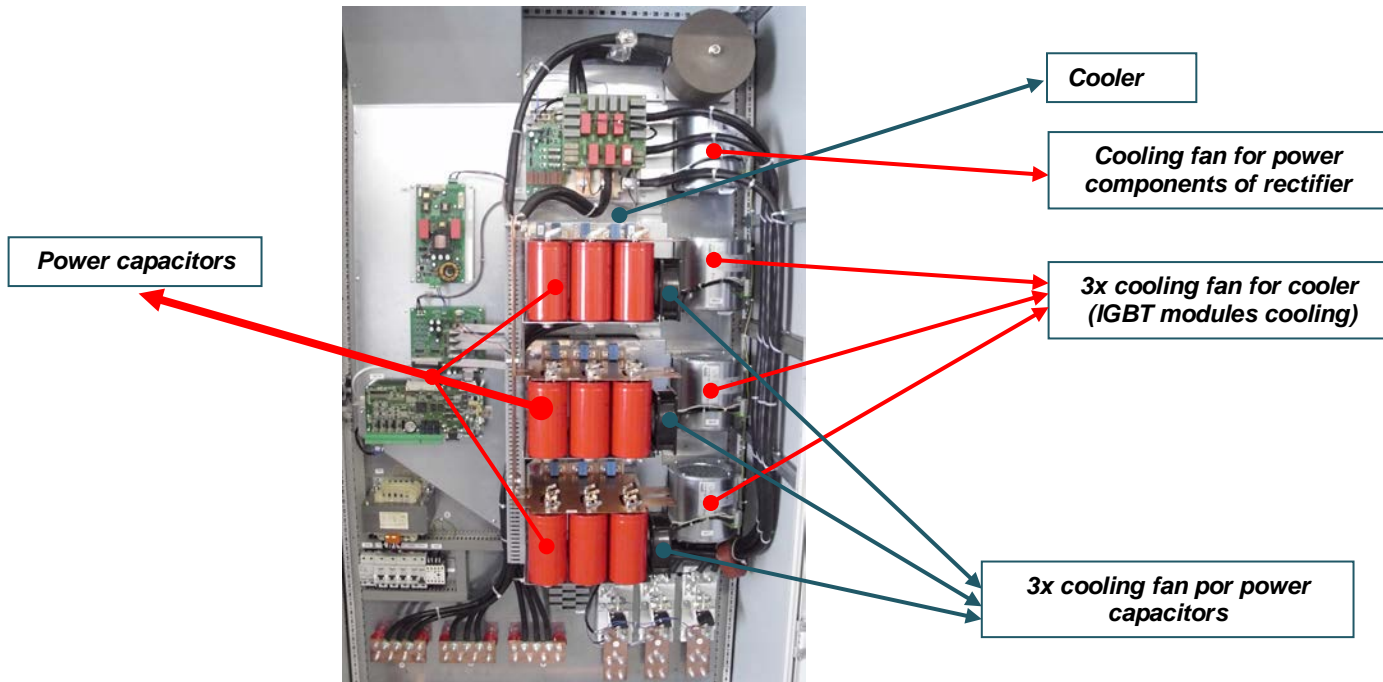

VONSCH company recommends following maintenance intervals quoted in the table:

Maintenance	Interval
<b>Capacitor forming</b> – if the converter has not been in use for more than a year. Electrolytical capacitors age with time, and therefore every capacitor that has been without voltage for more than a year needs to be formed, discharged and measured. Capacitor that is not formed appears to be faulty during measurement, even if its not. Special forming device needs to be used for this, so we recommend to order this service from the converter manufacturer. Loading by charging currents also affect the life span of the power capacitors. To extend the life span, commutation choke is used.	Every year (if the converter is out of service)
<b>Cooling fan replacement</b> – life span depends on the converter use and the environment temperature.	Every 5 years
<b>Checking the temperature and cleaning the heat loss circuit (cooler and fan)</b> – dust is settling on the cooler fins from the cooling air. If the cooler is dirty, the converter is overheating.	Every 6 to 12 months in a normal environment – not dusty or clean More often in a dusty environment
<b>Capacitor replacement</b> – life span depends on the converter load and the environment temperature.	Every 8 years

### 3 Technical specifications

#### 5 % $I_N$ – permissible continuous overcurrent

Converter type	Motor power $P_{nom}$ [kW]	Nominal output current of the converter $I_N$ [A]
UNIFREM 400 250	250	490
UNIFREM 400 315	315	580
UNIFREM 400 400	400	710
UNIFREM 400 500	500	880
UNIFREM 400 630	630	1150

Restriction limit of the output current of the converter from the PWM switching frequency (pulse-width modulation) defines the error limit - maximal IGBT current of the module. Operating area is limited from above by the maximal output current (5 %  $I_N$  – permissible continuous overcurrent) of the specific converter type depending on the drive or driven system (constant or variable load).

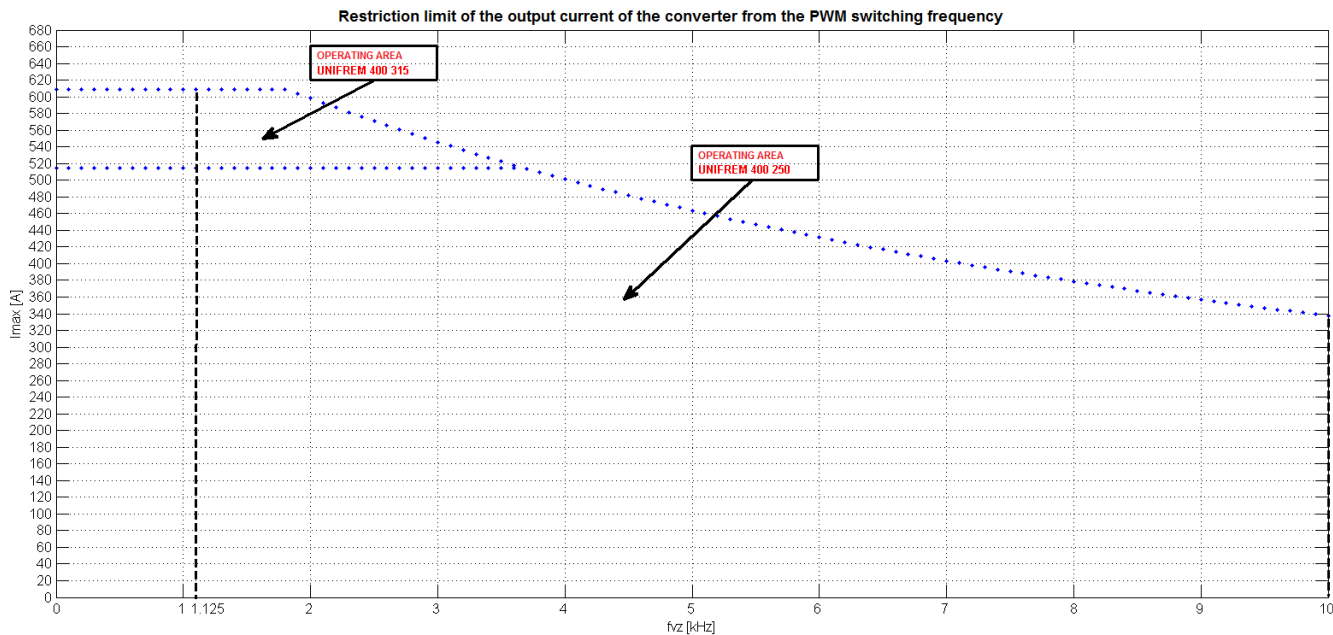

Restriction limit for the converter output current from the PWM switching frequency of converters UNIFREM 400 250, UNIFREM 400 315

\*Restriction limit for the converter output current from the PWM switching frequency for the converters with the power supply of 400V is set specially for the power of converter - 400, 500, 690 kW.

**Converter size:**

Converter type	height [mm]	width [mm]	depth [mm]	depth [mm] with UNIPANEL
UNIFREM 400 250 ÷ 315	2000+100	1000	600	635
UNIFREM 400 400	2000+100	1200	600	635
UNIFREM 400 500 ÷ 630	2000+200	1800	600	635

**3.1 General technical data**

<b>Supply voltage:</b>	3 x 380 - 415 V $\pm$ 10%
<b>Supply voltage frequency:</b>	47 to 63 Hz
<b>Output voltage:</b>	3 x 0 to 100% of the supply voltage
<b>Output frequency:</b>	0 ÷ 500 Hz
<b>Converter efficiency:</b>	More than 98,5 %
<b>Analog inputs:</b>	4 analog programmable inputs with possible options: 0 ÷ 20 mA, 4 ÷ 20 mA, 0 ÷ 10 V, 2 ÷ 10 V supply voltage for the potentiometer + 10 V (short circuit proof, current handling capacity max.15mA)
<b>Digital inputs:</b>	6 digital programmable inputs – working current 5,6 mA at both hardware voltage levels - 0V, 24V 1 digital safety input EN 13849-1 category 3 control voltage selectable by program + 24 V (current handling capacity - max. 125mA) or 0V
<b>Digital outputs:</b>	3 relay programmable outputs
<b>Analog outputs:</b>	3 analog programmable outputs 0 ÷ 20 mA or 4 ÷ 20 mA
<b>Motor starting torque:</b>	Up to 200 % Mn (depends on the motor type)
<b>Electronical protection of the converter:</b>	converter current overload, overvoltage in the power supply, undervoltage in the power supply, ground connection on the output, short circuit between the output phases, motor heat integral, converter heat overload, output and input phase disruption
<b>Cooling:</b>	Forced air cooling by the built in fans
<b>Electromagnetic compatibility (EMC):</b>	Built in RFI filter into the industrial environment EN 61 000-6-4
<b>Elimination of higher harmonic currents and voltages:</b>	Built in three phase choke decreases harmonic, extends the life span of the power capacitors, protects the converter against overvoltage peaks by the means of EN 61800-3
<b>Working temperature of the environment:</b>	+ 1 °C to + 40 °C (EN 50178 )
<b>Cover:</b>	IP 20, optional till IP55

## 4 Technical drawings

### 4.1 Connection diagram of the UNIFREM 400 frequency converters

Connection points of the frequency converter:

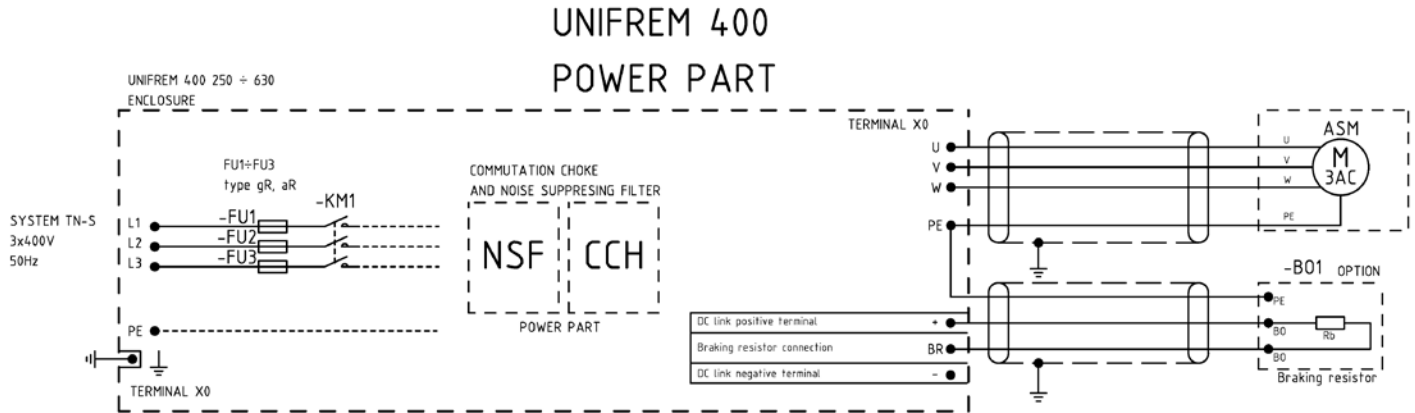

### UNIFREM 400 CONTROL PART

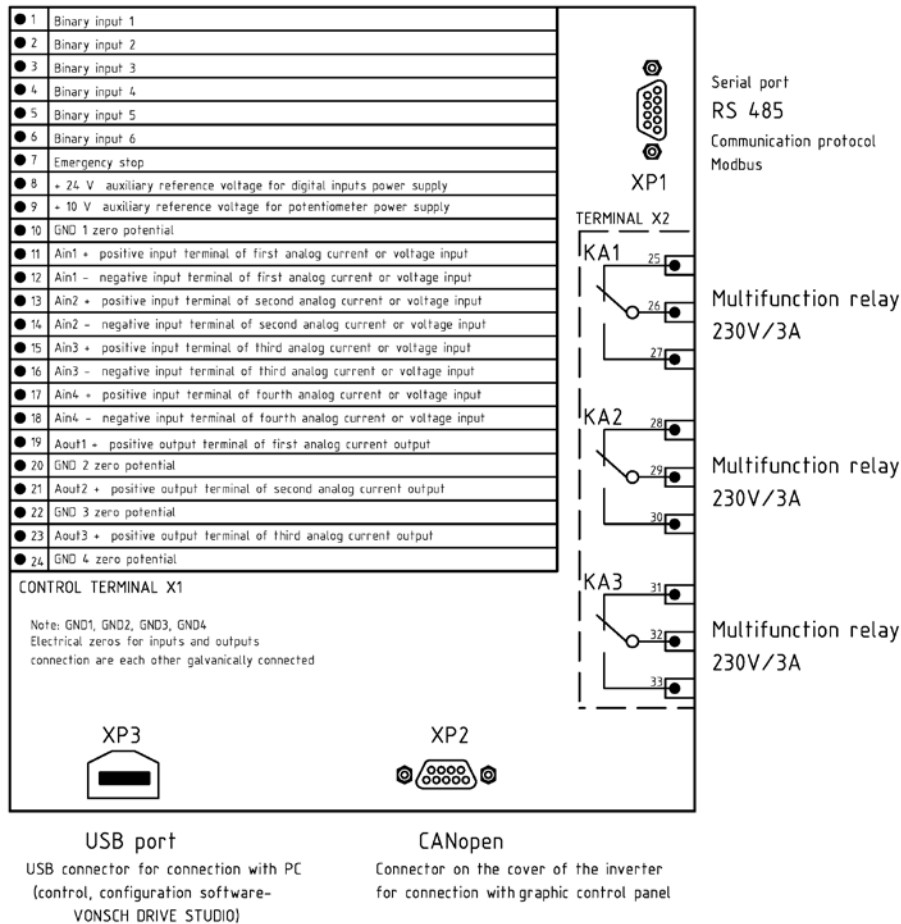

**Connection diagram of the UNIFREM 400 power terminal X0, processor board – position of the terminals, terminators and connectors:**

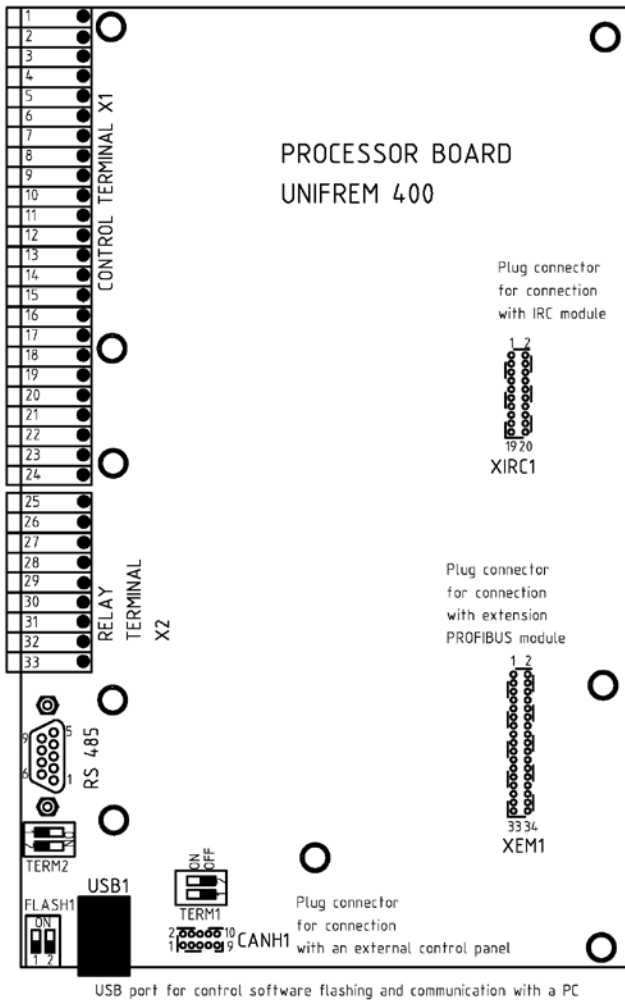
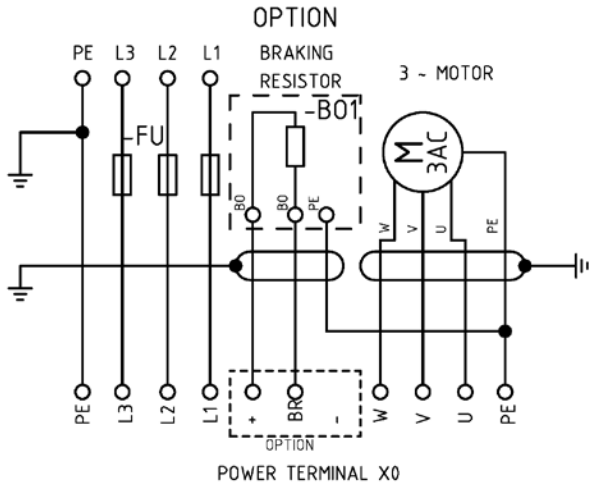

TERM1 - (TERMINATOR) Possibility to turn on termination resistor CAN and to turn on the supply voltage +24V to connected control panel UNIPANEL-1

- 1-ON - CAN termination resistor ON
- 1-OFF CAN termination resistor OFF
- 2-ON - turn ON the supply voltage +24V to control panel UNIPANEL-1
- 2-OFF turn OFF the supply voltage +24V to control panel UNIPANEL-1

TERM2 - serial link RS485 (TERMINATORS) termination resistors

- ON- turn on both switches if converter is at the beginning respectively at the end of the line
- 1,2 -turn off if converter is not at the beginning respectively at the end of the line

FLASH1 - DIP recording mode switch (firmware flash)



**UNIFREM 400 processor board view**

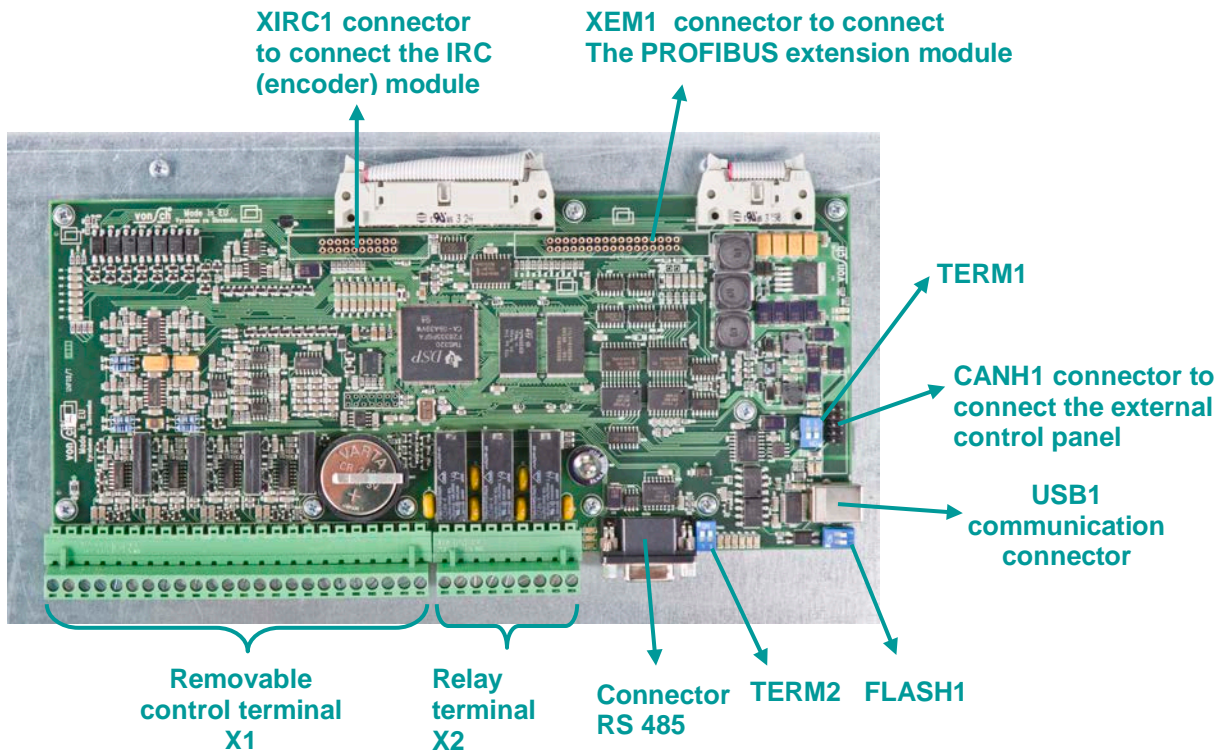



## 4.2 UNIFREM 400 converters terminals description and the way to connect the supply phases and the output phases from the converter

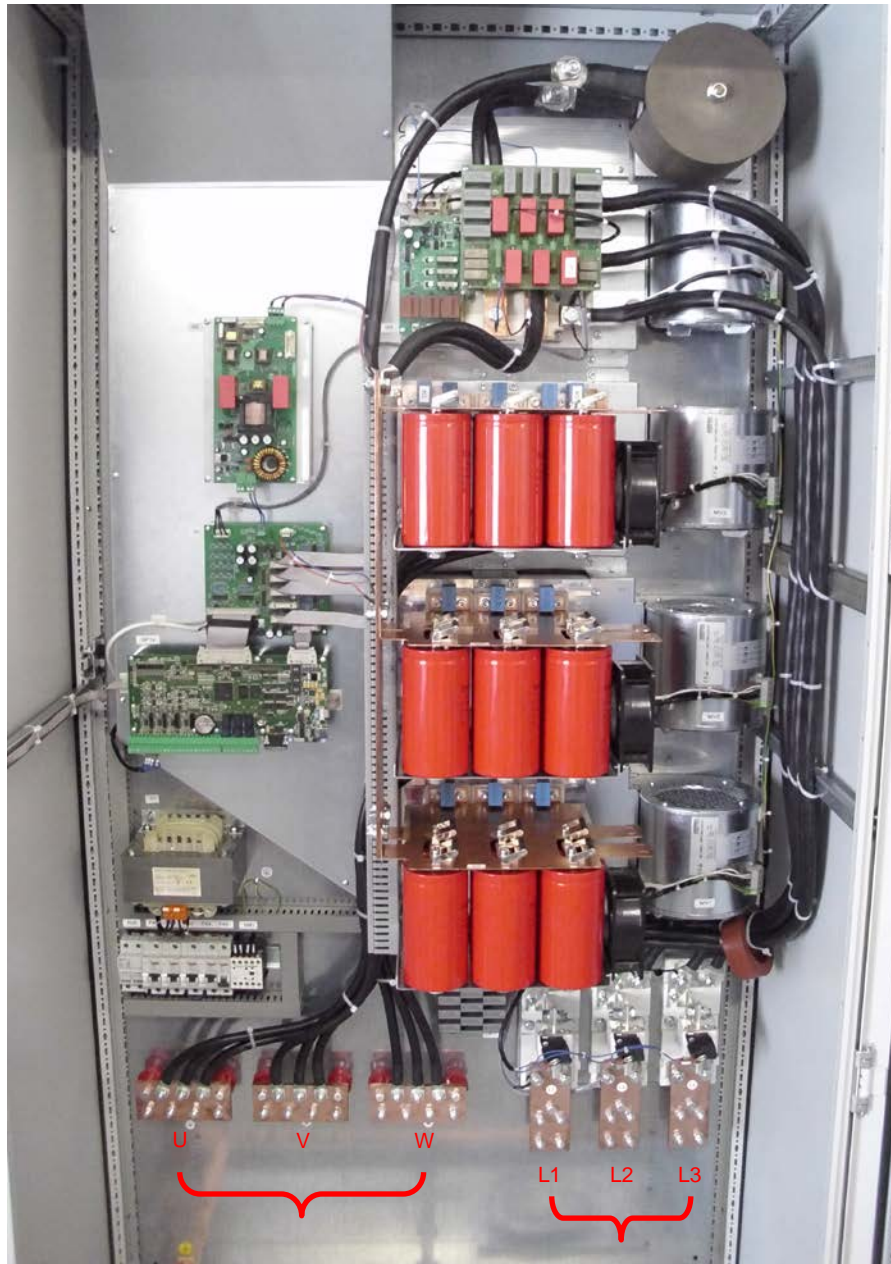

**Output  
phases**

**Input  
phases**

UNIFREM 400 250 ÷ 630  
Enclosure design

#### 4.2.1 Power terminal X0

	PE ●	Protective conductor of power supply	
	L1 ●	1. phase of supply voltage 3x380/400/415 V +/- 10 %	
	L2 ●	2. phase of supply voltage 3x380/400/415 V +/- 10 %	
	L3 ●	3. phase of supply voltage 3x380/400/415 V +/- 10 %	
DC power bus	+ ●	Positive terminal of of DC inter-circuit	<b>TERMINAL FOR BRAKING RESISTOR CONNECTION - OPTION</b> (optional accessories according to customer requirements)
	BR ●	Terminal for braking resistor connection	
	- ●	Negative terminal of DC inter-circuit	
	U ●	Output phase U from frequency converter	
	V ●	Output phase V from frequency converter	
	W ●	Output phase W from frequency converter	
	PE ●	Connection with protective terminal of appliance	

#### 4.2.2 Control terminal X1

1 ●	Binary input 1
2 ●	Binary input 2
3 ●	Binary input 3
4 ●	Binary input 4
5 ●	Binary input 5
6 ●	Binary input 6
7 ●	Emergency stop
8 ●	+ 24 V auxiliary reference voltage for digital inputs power supply
9 ●	+ 10 V auxiliary reference voltage for potentiometer power supply
10 ●	GND 1 zero potential
11 ●	Ain1 + positive input terminal of first analog current or voltage input
12 ●	Ain1 - negative input terminal of first analog current or voltage input
13 ●	Ain2 + positive input terminal of second analog current or voltage input
14 ●	Ain2 - negative input terminal of second analog current or voltage input
15 ●	Ain3 + positive input terminal of third analog current or voltage input
16 ●	Ain3 - negative input terminal of third analog current or voltage input
17 ●	Ain4 + positive input terminal of fourth analog current or voltage input
18 ●	Ain4 - negative input terminal of fourth analog current or voltage input
19 ●	Aout1 + positive output terminal of first analog current output
20 ●	GND 2 zero potential
21 ●	Aout2 + positive output terminal of second analog current output
22 ●	GND 3 zero potential
23 ●	Aout3 + positive output terminal of third analog current output
24 ●	GND 4 zero potential

GND1, GND2, GND3, GND4 - Electrical zeros for inputs and outputs connection are each other galvanically connected

### 4.2.3 Serial link RS485 – RS485 ( CANON ) port connection method

**RS485** - serial communication standard. RS485 is characterized by a two-wire units connection. The wires are labeled with letters A and B, but sometimes the designation "-" and "+" is used.

Conductor with a negative resting level "-" : **RxTx-** is connected to **PIN:8** of connector RS485 (CANON) on processor board UNIFREM.

Conductor with a positive resting level "+" : **RxTx+** is connected to **PIN:3** of connector RS485 (CANON) on processor board UNIFREM.

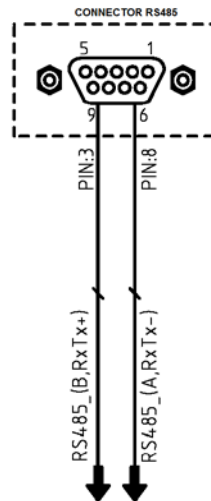

### 4.2.4 External control examples for the X1 terminal using binary inputs

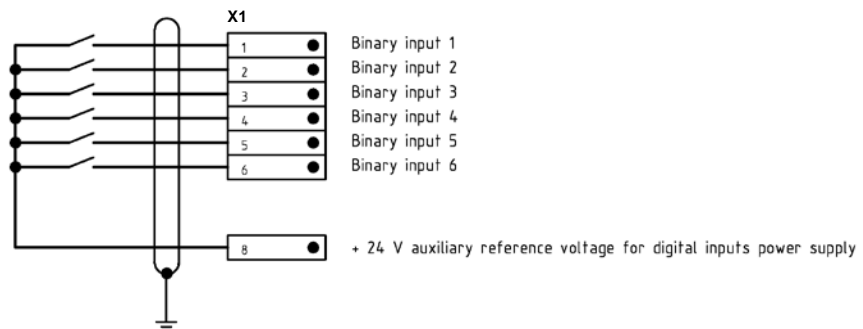

Binary inputs X1:1, X1:2, X1:3, X1:4, X1:5, X1:6 are active if voltage 24V is connected to them according to the hardware evaluation type of the binary inputs.

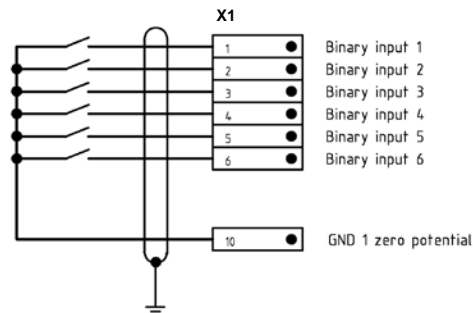

Binary inputs X1:1, X1:2, X1:3, X1:4, X1:5, X1:6 are active if voltage 0V is connected to them according to the hardware evaluation type of the binary inputs.

**\* Working current of the binary inputs is 5,6 mA at both hardware voltage levels - 0V, 24V !**

#### 4.2.5 Method of connecting the potentiometer to the X1 terminal

Potentiometer is connected to the free analog input AINx of converter terminal. AINx is set to the voltage analog input 0-10V.

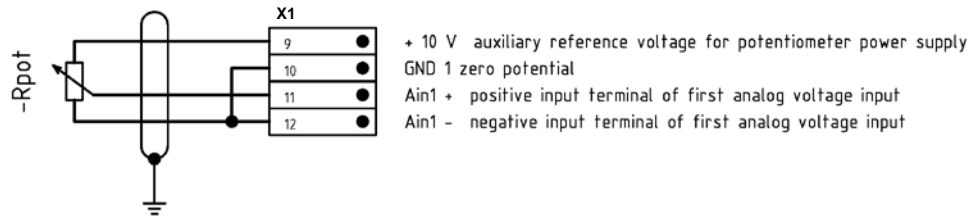

#### 4.2.6 Method of connecting the analog inputs of converter

Example of current analog output (0-20mA or 4-20mA) connection from control system to any free converter analog input AINx.

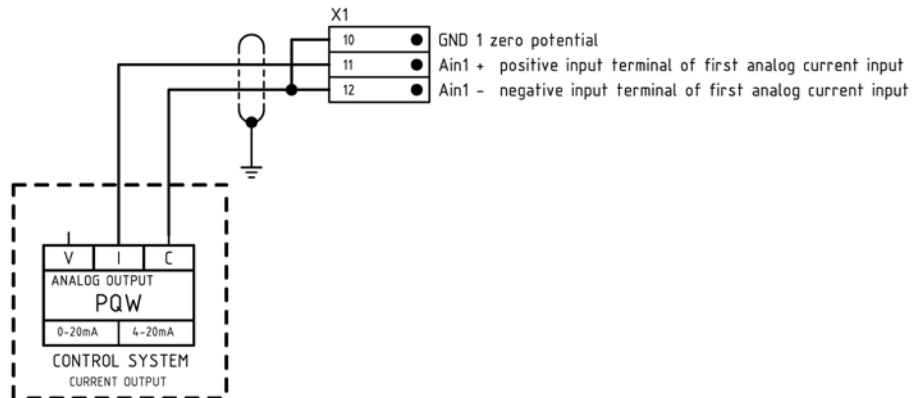

Example of voltage analog output (0-10V or 2-10V) connection from control system to any free converter analog input AINx.

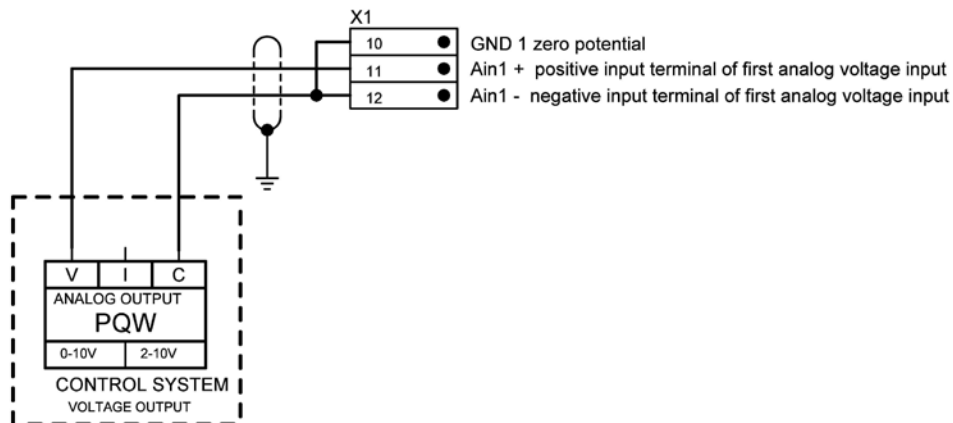

#### 4.2.7 Method of connecting the analog outputs of converter

Converter analog output operates in current range of 0-20 mA or 4-20 mA.

Connection example - analog input of control system can be connected to the free analog output AOUTx of converter.

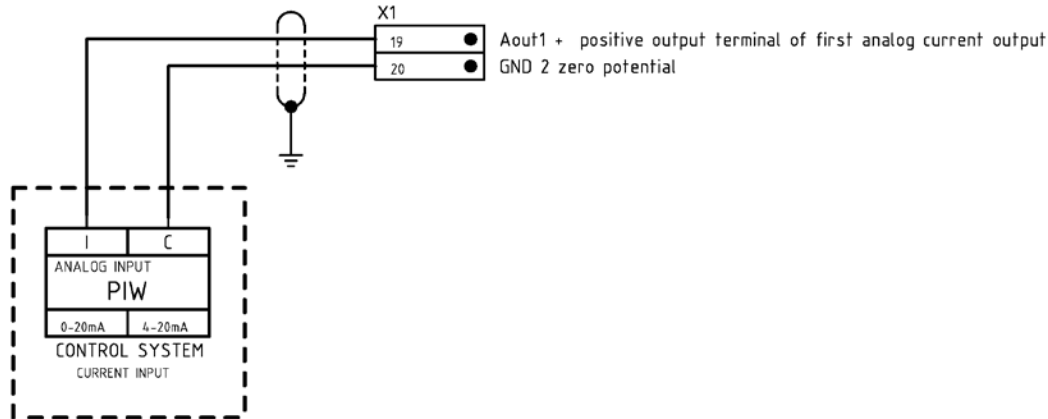

#### 4.2.8 Method of connecting sensors to the X1 terminal

Sensors convert physical parameters to electrical signals. The physical state that is to be measured must first be transformed into a unified form - unified electrical signal.

After connecting the sensor of any physical quantity (temperature, pressure, level, flow ..) to any free analog input terminal (AIN1, AIN2, AIN3, AIN4) of frequency converter UNIFREM 400, the output signal is used for management, diagnosis, or as a feedback for frequency converter process PID regulator.

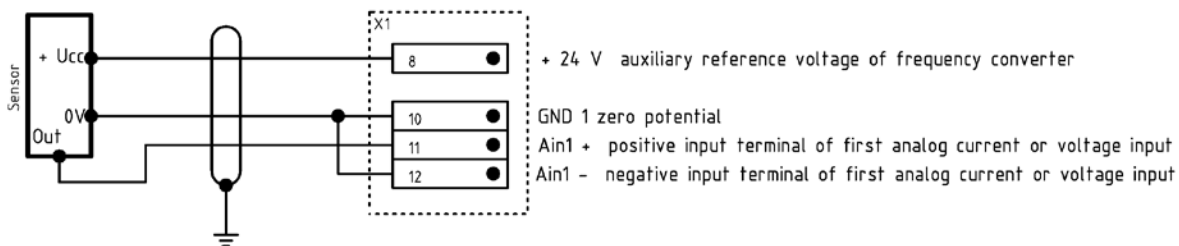

3 – conductor connection of a sensor using the converter supply voltage of +24V

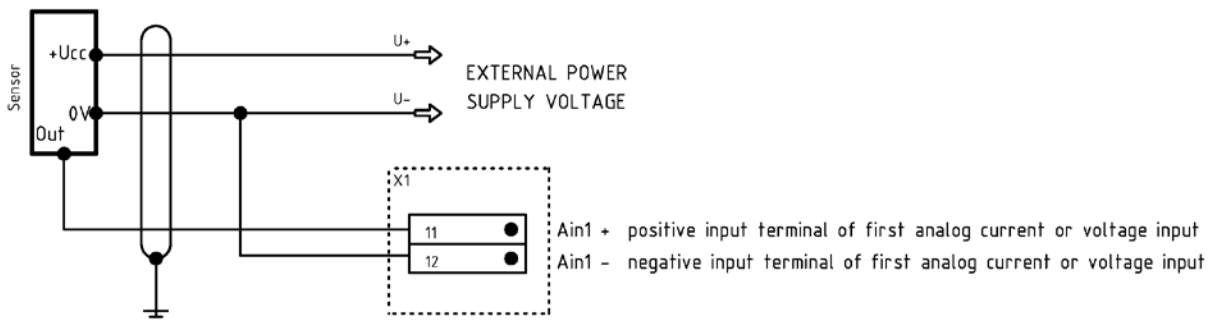

3 – conductor connection of a sensor using the external power supply

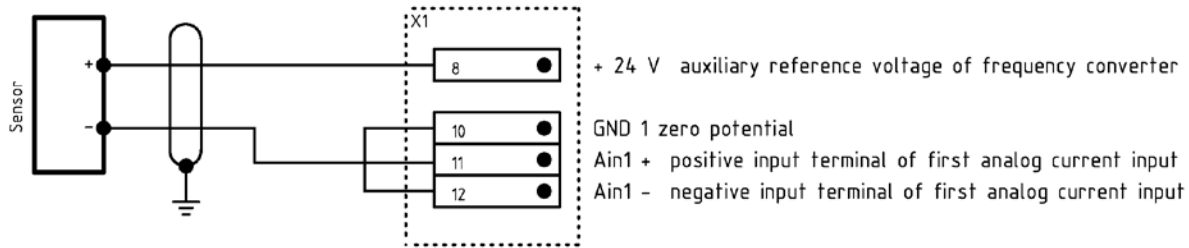

*2 – conductor connection of a sensor using the converter supply voltage of +24V, analog input type is 4-20 mA current*

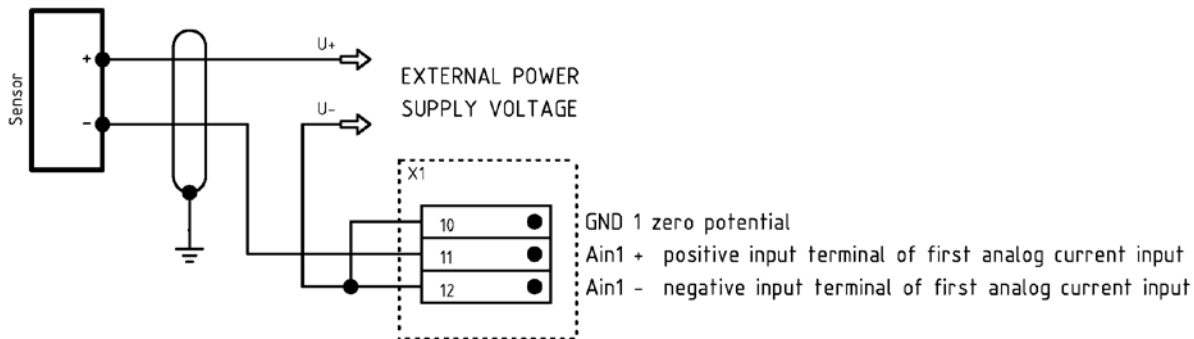

*2 – conductor connection of a sensor using the external power supply, analog input type is 4-20 mA current*

#### 4.2.9 Connecting temperature sensors of the motor - PT100 , PTC to the X1 terminal

If on the device, which includes a frequency converter a temperature sensor or a set of several sensors of the same type are available, they can be connected to the converter and evaluate a device temperature from them, if necessary, warnings and errors. One analog input (free) and one analog output (free) is used to connect temperature sensors PTC, PT100. The optimum excitation current which is selected as a signal of appropriate AOUTx causes voltage drop on AINx. Sensor temperature resistance and subsequently temperature is evaluated from this data.

4-wire temperature sensor connection is not only more resistant to interference, but also eliminates the voltage drops on long cables, thus increasing measurement accuracy. Larger cable cross sections should be used at 2-wire temperature sensor connection. Parallel connection AOUTx and AINx should be connected directly on the terminal X1 of converter processor board at 2-wire temperature sensor connection.

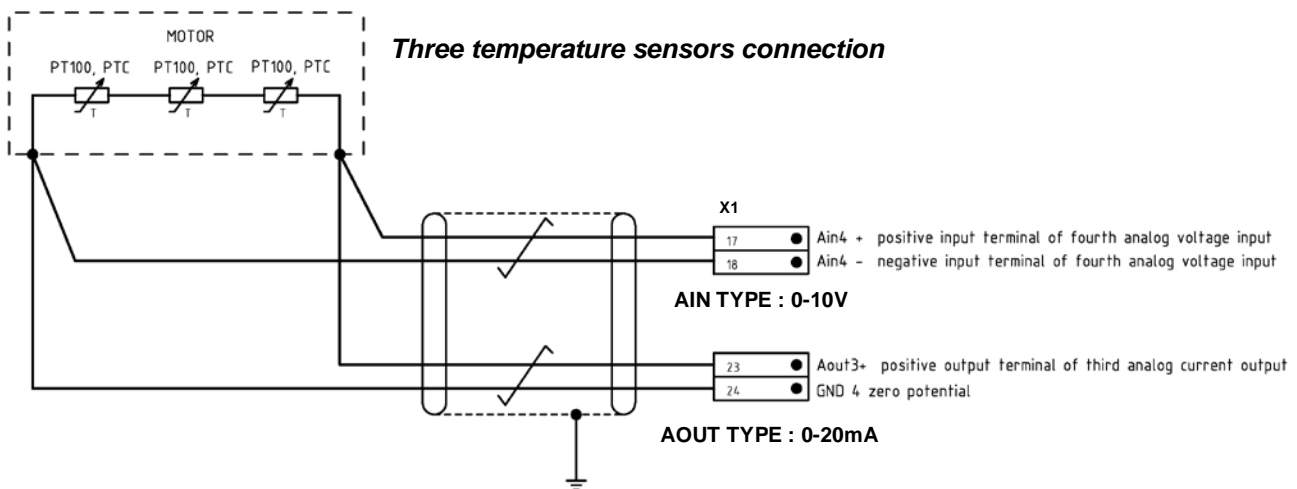
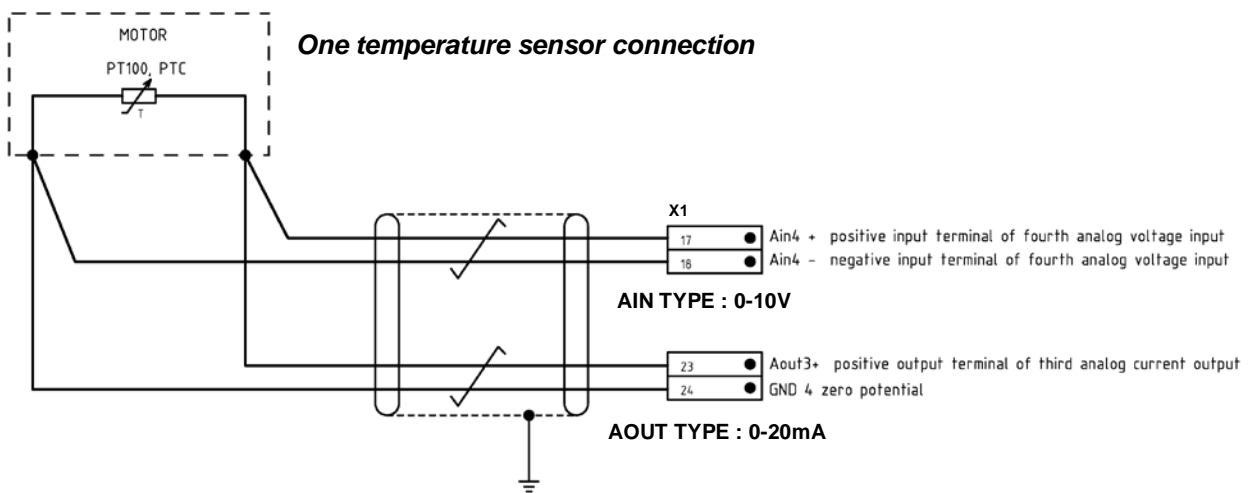

#### 4.2.10 Connecting measuring and display devices to the analog output of the X1 terminal

Converter analog output AO1, AO2, AO3 operates in the range of 0-20 mA or 4-20 mA. Measuring and display devices can be connected to any free analog output AOUTx.

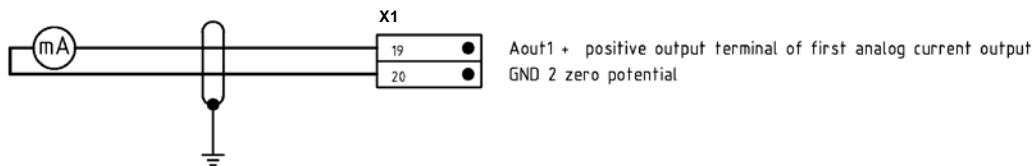

Analog display unit

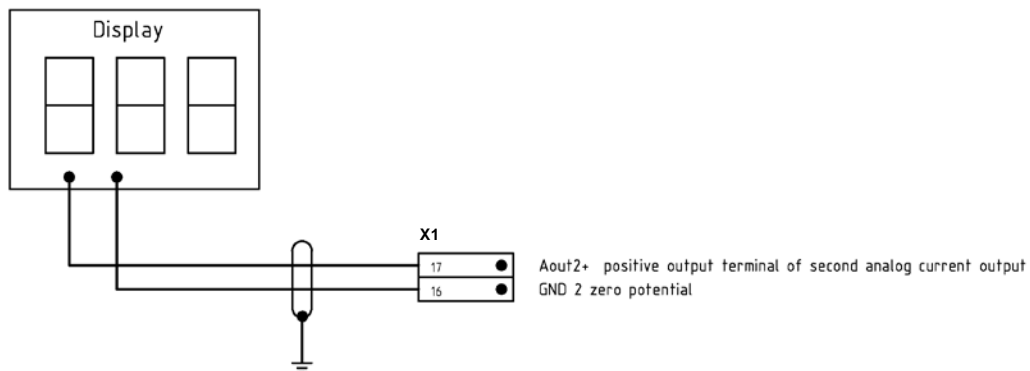

Digital display unit



### 4.2.11 Relay terminal X2

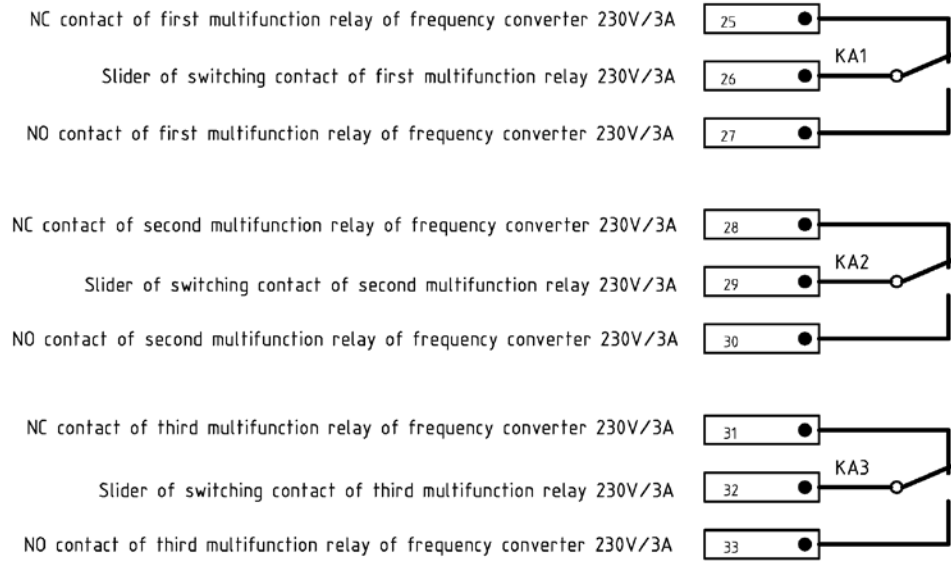

### 4.2.12 Example of a relay connection option KA1, KA2, KA3

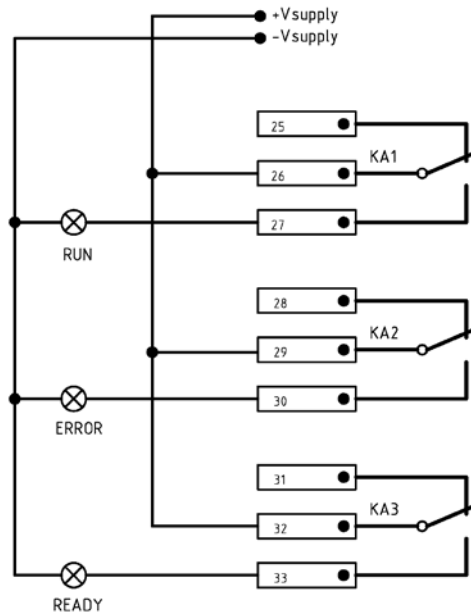



### 4.3 Dimensioning of braking resistors

Correctly dimensioned braking resistors allow to converter to consume energy from the rotating motor (at fast motor braking - during deceleration of inertial masses of drive with motor frequency reducing and in regenerative operation mode) to the heat. Braking module of frequency converter is above-standard equipment and is installed at the customer's request.

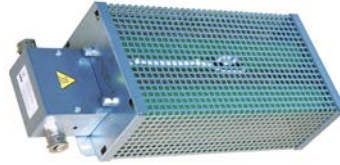

**\*Braking resistor for motor power over 75kW is dimensioned according to the customer requirements**

### 4.4 Sine filter

Sine filter filters the output impulse voltages of the converter to a voltages of sinusoidal shape with changing frequency and amplitude. This will eliminate capacitor current peaks and the motor insulation stress. To ensure a perfect interference suppression of converter output, it is necessary to use shielded cable or special EMC sine filter. Using a special EMC sine filter it is not necessary to use a shielded cable on the converter output. In case of use sine filter, it is necessary to set the IGBT transistor sampling frequency to at least 4 kHz!



**\*Sine filter for motor power over 110kW is dimensioned according to the customer requirements**

### 4.5 Motor chokes

Output motor chokes are used when a non shielded MOTOR-CONVERTER cable is used and over 100m in length and when a shielded MOTOR-CONVERTER cable is used and over 50m in length. Every choke is attached to the mounting plate with a separate screw. Screw is a part of the choke. Feed cables are mounted to the choke cable lugs. When a longer cable is used, it is necessary to take precautions to eliminate the effects of the cable length on the converter operation. Mounting a motor choke or a sine filter will eliminate the cable capacity effect.

**\*Motor choke for motor power over 110kW is dimensioned according to the customer requirements**

## 4.6 IRC connection to frequency converter UNIFREM 400

IRC (RM-UNI\_IRC1) extension module with plug-in connector XIRC1 for connection with UNIFREM processor board. Incremental encoder is connected to the marked terminal on IRC extension module. It is used in vector - closed control of speed, torque or position. Push-pull incremental rotary encoder HTL type with 24VDC power supply is used to connect to the module. The extension module contains some sensor errors control (for example wrong signals) directly in itself.

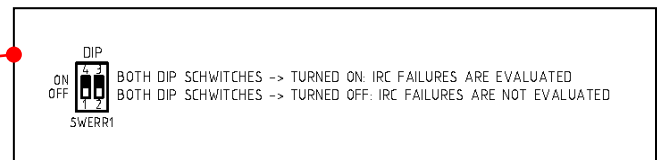
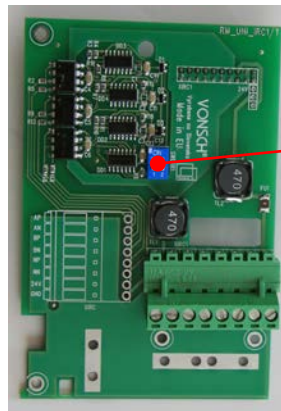
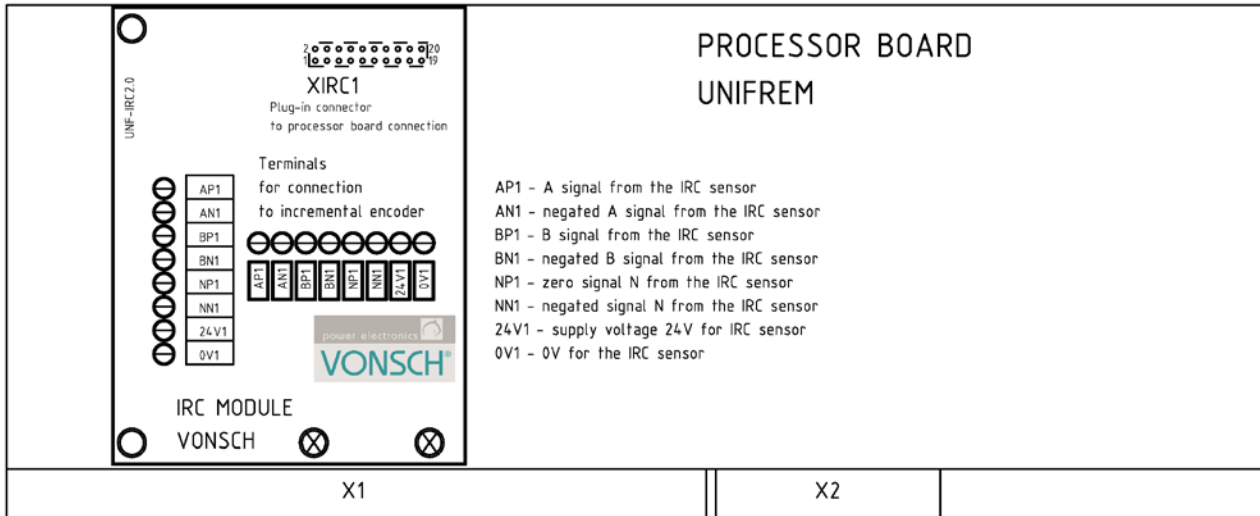

**Extension module RM-UNI\_IRC1  
for connection to frequency converter  
UNIFREM 400**

## 4.7 UNI-PB DP extension module to connect the converters to PROFIBUS DP

Profibus\_UNI extension module is used to connect converters to PROFIBUS DP. Communication protocol DP (Decentralized Peripherals) was designed to quick data exchange directly in the application. It is a place where central programmable controllers like PLC or process control systems communicate with a decentralized distributed peripheral device - frequency converter over a very fast serial connection. Module is connected through a plug in connector XEM1 to the UNIFREM processor board.

connector PROFIBUS

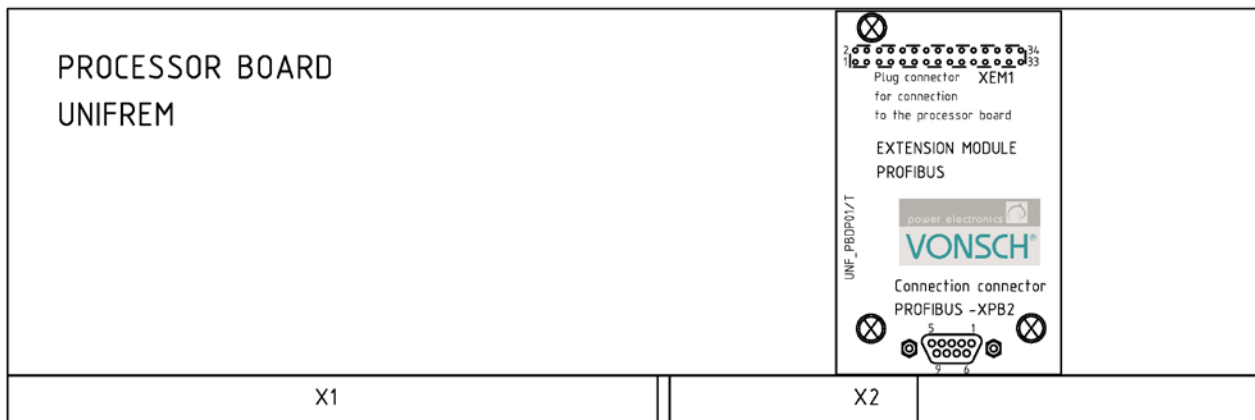
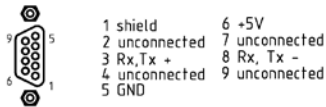

Extension module Profibus\_UNI  
for connection to frequency converter  
UNIFREM 400

## 4.8 Resolver sensor type connection to frequency converter UNIFREM 400

RM-RDC extension module with plug-in connector XIRC1 for connection with UNIFREM processor board. Resolver is connected to the marked terminal XRES1 on extension module. It is used in vector - closed control of speed, torque or position for asynchronous or synchronous motors. The extension module contains some sensor errors control and detection (for example wrong signals, disconnected signals and too much disturbance) directly in itself.

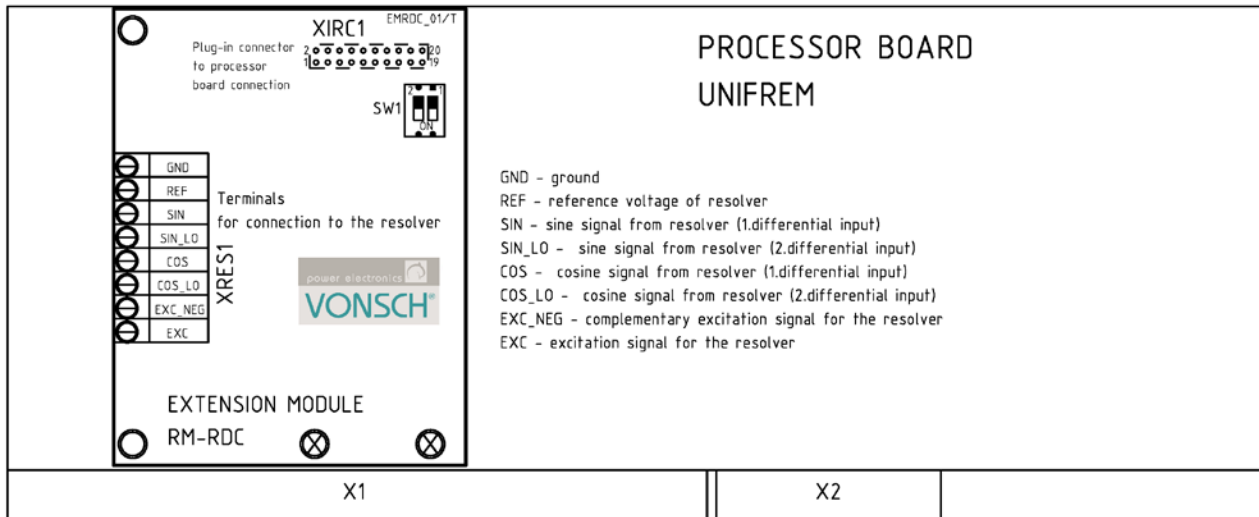

f [kHz]	SW1.1	SW1.2
10	off	off
12	off	on
15	on	off
20	on	on

Programmable frequency of sine excitation signal for the resolver with DIP switch SW1

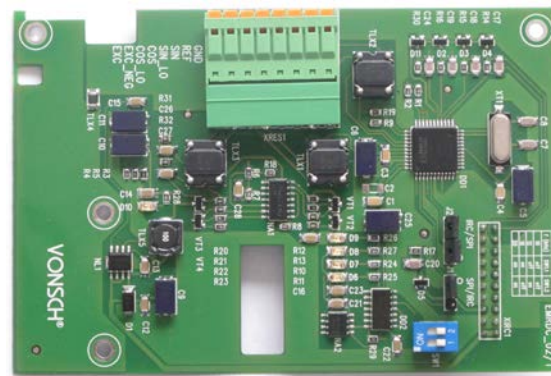

**Extension module RM-RDC for connection to frequency converter UNIFREM 400**

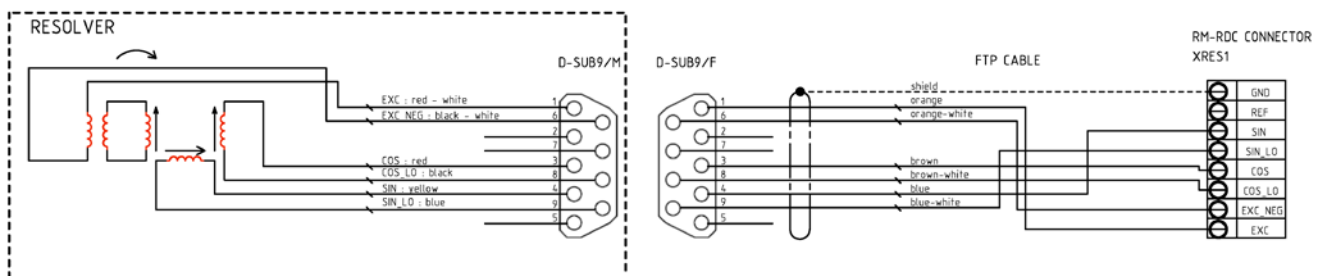

Connection type of resolver on the connector XRES1 of the extension module

## 4.9 UNIFREM 400 converter connection using a serial line

At the beginning and the end of the line, termination resistors are turned on.

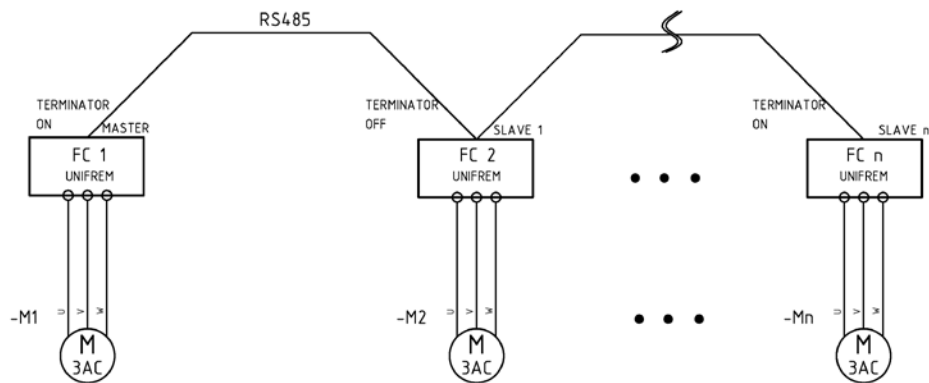
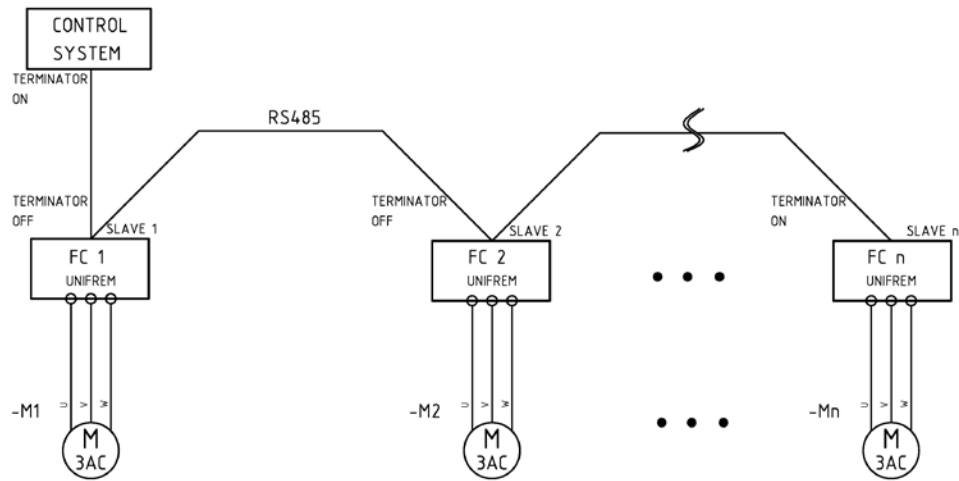
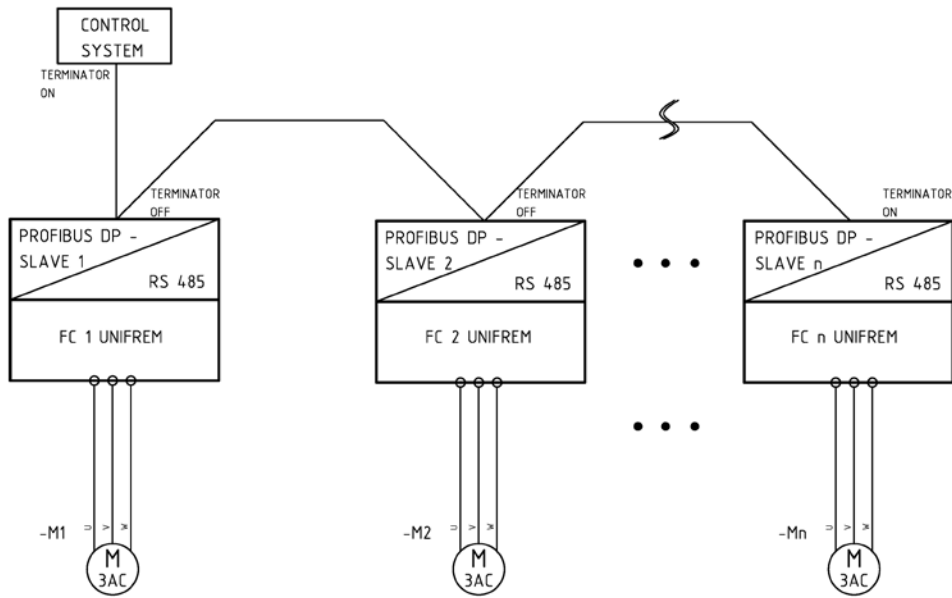

## 4.10 OPTION (optional accessories)

### 4.10.1 Removable control panel UNIPANEL-1



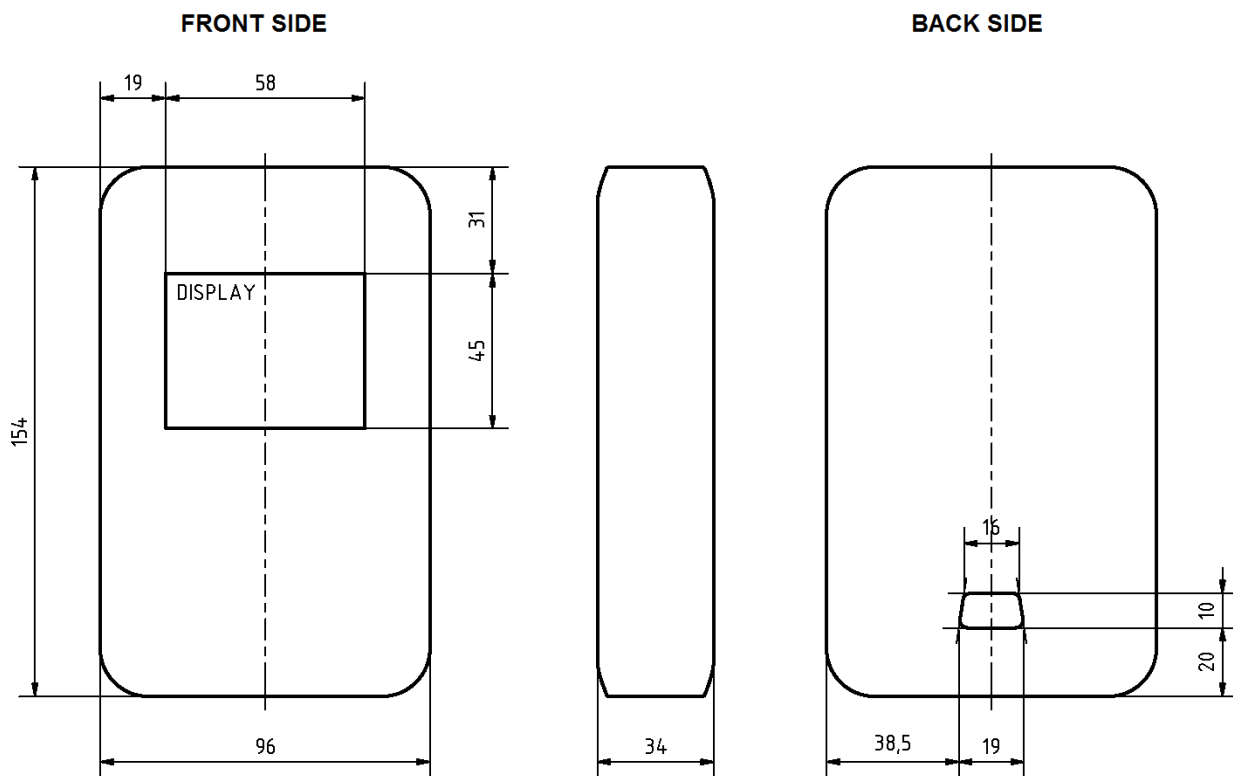

UNIPANEL-1 control panel front view



UNIPANEL-1 control panel dimensions

### 4.10.2 Connecting multiple frequency converters to the UNIPANEL-1 control panel

CANON	HEADERS		Note
			
1	1	NC	The selectable jumper
2	3	CAN L	Necessary to connect between all converters FM 1..FM n a UNI1
3	5	CAN-GND	Necessary to connect between all converters FM 1..FM n a UNI1
4	7	NC	The selectable jumper
5	9	CAN-SHLD	Necessary to connect between all converters FM 1..FM n a UNI1
6	2	GND	Necessary to connect between all converters FM 1..FM n a UNI1
7	4	CAN H	Necessary to connect between all converters FM 1..FM n a UNI1
8	6	NC	The selectable jumper
9	8	24 V	Connection only between FM n a UNI1
	10	NC	The selectable jumper

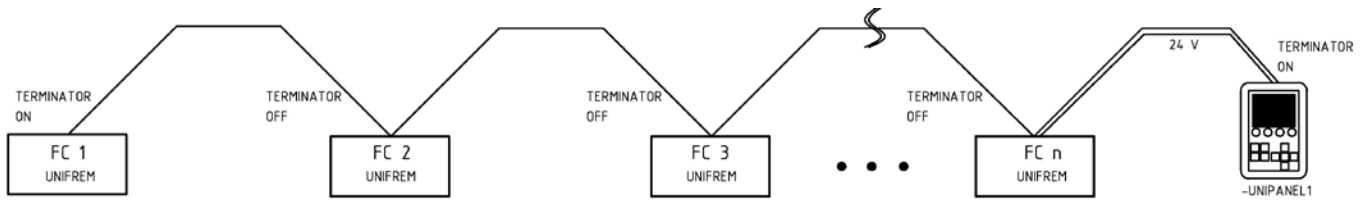

## 5 The procedure for uploading firmware

### Preparing the program interface in the computer:

- download the C2Prog program from the <http://www.codeskin.com/programmer> webpage
- install the program using setup.exe
- if necessary, install java from <http://www.java.com>
- install the converter driver from [http://soft.vonsch.sk/data/Software/RS485\\_USB2drv.zip](http://soft.vonsch.sk/data/Software/RS485_USB2drv.zip)

### Prepare the firmware:

- download the latest firmware for the given device from the [www.vonsch.sk](http://www.vonsch.sk) webpage

### Installation:

- backup the converter parameters using the control panel
- turn off the converter (wait for the actual stop)
- turn on the DIP switch on the processor board to installation mode (flash) – position ON

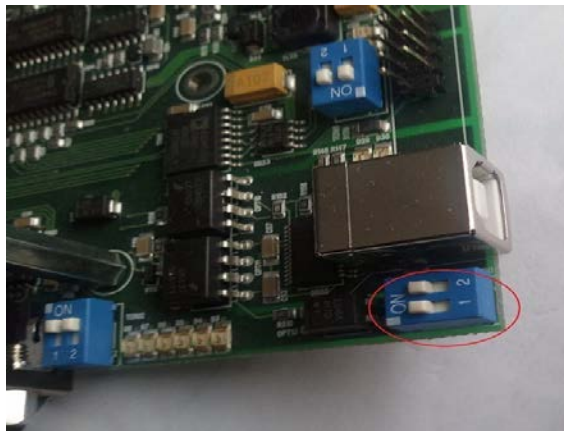

- connect the converter to a computer using an USB cable - USB cords A / B
- set the proper COM port in Windows  
 “Control panel / System and security / System / Device manager / Pors (COM and LPT) / USB serial port / Port Settings/ Advanced/ Port number” na COM1
- turn the converter on
- start the program C2Prog



- select the desired firmware (Select File)

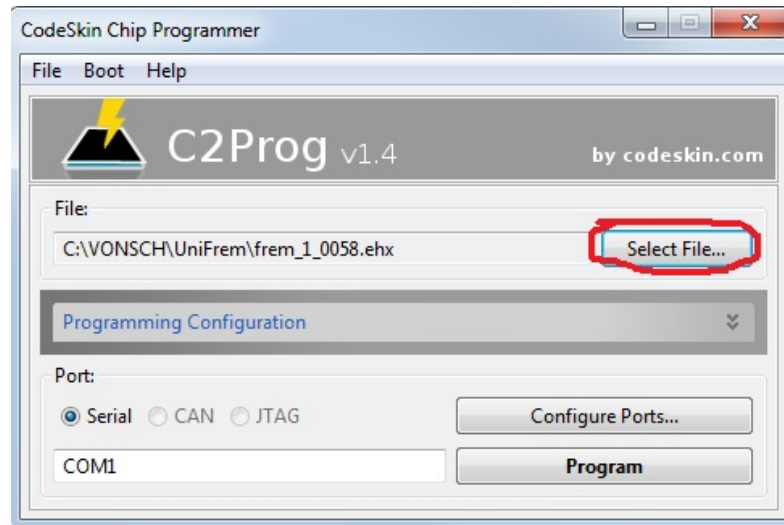

- **start the software installation using the “Program” button**
- installation progress window opens
- if the text describing the installation does not appear in this window for longer than a minute, close the window and check port settings (COM1 is probably not configured)
  - o select the button “Configure Ports”
  - o then, select “Scan Ports”
  - o wait for the finish
  - o select the proper COM port
  - o confirm by OK
  - o start the installation again

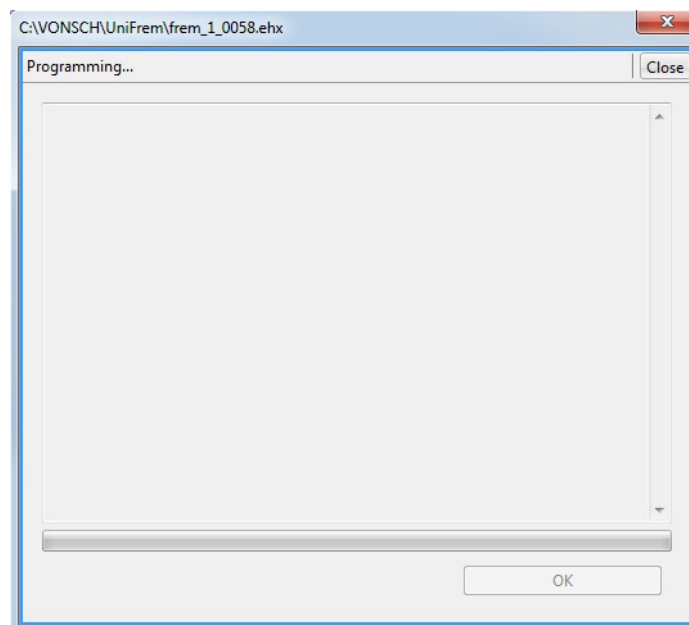

- wait for the installation to finish

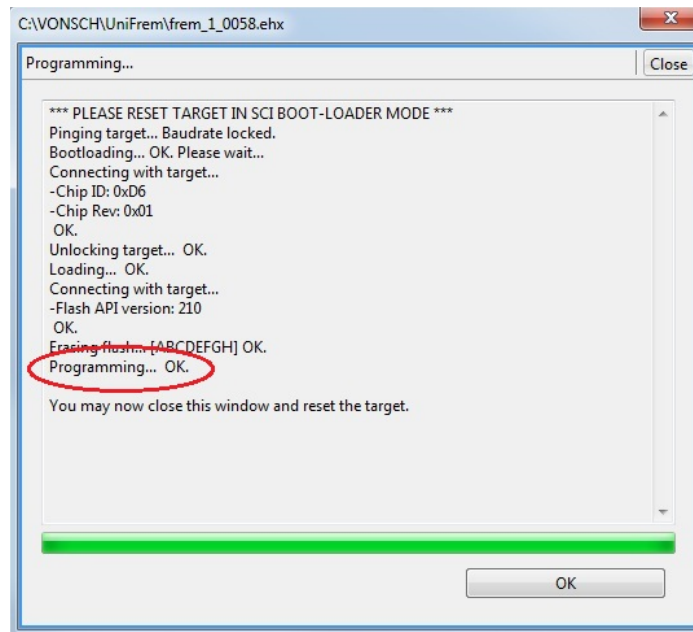

- turn off the converter (wait for the actual stop)
- disconnect the USB cable
- switch off the DIP switch to install – position 1, 2
- turn the converter on (wait for the new software to initialize for approximately 30 seconds)

## 6 Appendix

### 6.1 Quality certificate – organization management system





## 6.2 ES Declaration of conformity

### 6.2.1 european harmonized standards

#### 1, ES declaration of conformity is issued by:

**Manufacturer:** VONSCH spol. s r.o.  
**Seat :** Budovateľská 13, 977 03 BREZNO  
**CRN:** 31567835  
**CRN FOR VAT:** SK 2020453226

#### 2, PRODUCT NAME: Frequency converter of the type:

**UNIFREM 400 250, UNIFREM 400 315, UNIFREM 400 400,  
 UNIFREM 400 500, UNIFREM 400 630**

#### 3, Description and designation of the product:

UNIFREM 400 xxx type frequency converter is designed for speed control of asynchronous and synchronous motors by changing the frequency and amplitude of the terminal voltage of the motors.

#### 4, WE DECLARE AND CONFIRM:

Frequency converter type of UNIFREM 400 xxx passed functional tests, EMC and security tests by the manufacturer VONSCH spol. s r.o. **ES declaration of conformity** on the converter types stated in point 2, is issued by the VONSCH s.r.o. company based on VONSCH tests and production documentation. Product stated in point 2, complies with the approved technical documentation. Provided it is used for the manufacturer designed purposes, it is properly maintained and was installed according to provided technical documentation and corresponding warnings stated in this documentation, this product is safe.

UNIFREM 400 xxx frequency converter was designed, produced, evaluated and tested according to these european harmonized standards:

**EN 50178, EN 61800 – 3, EN 61439 – 1, EN 60721-3-3 (cat. 3C3)**

**UNIFREM 400 xxx frequency converter complies with ES directives:**

**For low voltages:** 2014/35/EEC  
**EMC:** 2014/30/EEC  
**RoHS:** 2011/65/EEC

In Brezno, on the day of: 18.5.2010

Ing. Ivan VONKOMER – CEO of the company



**vonsch s.r.o.**  
 Budovateľská 13, 977 03 Brezno  
 www.vonsch.sk • vonsch@vonsch.sk  
 31567835 • SK2020453226

## ES declaration of conformity

### 6.2.2 slovak and european harmonized standards

**Manufacturer:** VONSCH spol. s r.o.  
**Seat :** Budovateľská 13, 977 03 BREZNO  
**CRN:** 31567835  
**CRN FOR VAT:** SK 2020453226

### 2, PRODUCT NAME: Frequency converter type:

**UNIFREM 400 250, UNIFREM 400 315, UNIFREM 400 400,  
 UNIFREM 400 500, UNIFREM 400 630**

### 3, Description and designation of the product:

**UNIFREM 400 xxx** type frequency converter is designed for speed control of asynchronous and synchronous motors by changing the frequency and amplitude of the terminal voltage of the motors.

### 4, WE DECLARE AND CONFIRM:

Frequency converter type of **UNIFREM 400 xxx** passed functional tests, EMC and security tests by the manufacturer VONSCH spol. s r.o. **ES declaration of conformity** on the converter types stated in point 2, is issued by the VONSCH s.r.o. company based on VONSCH tests and production documentation. Product stated in point 2, complies with the approved technical documentation. Provided it is used for the manufacturer designed purposes, it is properly maintained and was installed according to provided technical documentation and corresponding warnings stated in this documentation, this product is safe.

**UNIFREM 400 xxx** frequency converter was designed, produced, evaluated and tested according to these slovak and european harmonized standards:

**STN EN 61800 – 3, STN EN 50178, STN EN 61439 – 1, STN EN 60721-3-3 (cat. 3C3)**

Features of these products are in compliance with:

**SR Government regulations nr.:148/2016 B. of I., 127/2016 B. of I. .**

**UNIFREM 400 xxx frequency converter complies with ES directives:**

**For low voltages:** 2014/35/EEC  
**EMC:** 2014/30/EEC  
**RoHS:** 2011/65/EEC

In Brezno, on the day of: 18.5.2010  
 Ing. Ivan VONKOMER – CEO of the company



**vonsch s.r.o.**  
 Budovateľská 13, 977 03 Brezno  
 www.vonsch.sk • vonsch@vonsch.sk  
 31567835 • SK2020453226